

Smart Home Energy Management System based on a Hybrid Wireless Network Architecture

Zakariae Jebroni^{1,*}, Jose A. Afonso² and Belkassem Tidhaf¹

¹Laboratory of Embedded Electronics Systems and Renewable Energy (SEEER), University Mohammed Premier, Morocco

²CMEMS-Uminho Center, University of Minho, Portugal

Abstract

Currently, in electrical energy sector, due to the population growth and the increasing energy consumption demand, the electrical grid is becoming more and more complex. This creates new challenges in term of electrical energy management. Our contribution in this area, presented in this paper, consists of the design, implementation and test of a wireless monitoring and control system for household electrical appliances. This system offers to the residential customers a helpful tool to monitor and control the energy consumption of their household appliances. The developed system is composed by a set of components connected to each other using wireless network technologies: the monitoring devices, the gateway and the client devices (with the respective user interface). For the development of this system, we opted to use a hybrid wireless network solution based on Wi-Fi and Bluetooth Low Energy (BLE). We describe the design and the implementation of the monitoring device hardware, as well as the calculation methodologies to obtain the electrical quantities and to reduce as much as possible the measurement errors. This paper describes also the development of the BLE/Wi-Fi gateway and the Graphical User Interface (GUI). The performance of the developed monitoring device was evaluated by means of experimental tests, where we achieved a voltage measurement error below 0.2% and a current measurement error below 0.5%.

Keywords: Monitoring Device, Energy Management System, Smart Home, Bluetooth Low Energy.

Received on 01 April 2019, accepted on 30 October 2019, published on 15 November 2019

Copyright © 2019 Zakariae Jebroni *et al.*, licensed to EAI. This is an open access article distributed under the terms of the Creative Commons Attribution licence (<http://creativecommons.org/licenses/by/3.0/>), which permits unlimited use, distribution and reproduction in any medium so long as the original work is properly cited.

doi: 10.4108/eai.13-7-2018.161437

1. Introduction

In the past, when the first electrical grids were implemented back to the late 1800s [1], and until the 1960s, the energy consumption demand was moderate. At that time, in terms of measurement and management, the electricity operators used only basic equipment to manage the electrical grid, such as electromechanical energy meters to measure the energy production and consumption. These devices needed human intervention to read the energy consumption and to turn on/off generators. In addition, the management of the energy consumption was not given attention from the consumer side. As the number of customers increased, from the last decades of the 20th century, the demand of electricity has increased and the electrical grid became much more complicated. Therefore, it was necessary to implement new solutions, based on emerging technologies,

in order to better manage and control the energy production-consumption chain [1].

Currently, electricity operators are moving from static systems to intelligent and real-time management systems [2], [3]. These systems form an Advanced Metering Infrastructure (AMI) and provide features such as energy theft detection, CO₂ emissions reduction (through increased awareness of energy consumption, while facilitating the integration of renewable energy sources), remote control and command of the electrical grid, as well as energy production savings, as much as possible, due to balancing production in real time according to consumption. Nevertheless, the population growth, urbanization and irrational use of electrical energy increase its consumption, which makes the management of electrical energy on the production side more challenging, especially if the consumer side is not taken into account. By managing and controlling the energy consumption at the consumer side, more efficient and satisfactory results

*Corresponding author. Email: zakariae.jebroni@gmail.com

may be achieved. Firstly, by reducing the consumption on the consumer side, the electricity bill will be reduced. Secondly, real-time management and forecasting, through intelligent management systems in the production side, will provide electricity operators with a solid basis for balancing the production-to-consumption ratio over long term and, therefore, managing energy sources efficiently. Finally, from the environmental side, by reducing the energy consumption and losses, the CO₂ emissions will also be reduced.

In order to manage the energy consumption on the consumer side, a Smart Home Energy Management System (SHEMS) is required. In this sense, the system presented in this paper gives the consumers a robust tool to manage and control their energy consumption, through the inclusion of functionalities that allow the monitoring and control of the household appliances and enable reducing the power demand. The SHEMS may be connected to the Smart Grid Management System (SGMS), allowing the electricity operator to have information regarding the customers' behavior and energy consumption. Alternatively, even if the consumers' information is kept confidential, the SHEMS may still be indirectly helpful to AMI, by reducing the energy consumption, which benefits both parts (reducing energy production requirements on the production side and reducing the electricity bill on the customer side).

The developed SHEMS is an embedded system composed by a wireless monitoring and control system and a smart algorithm to manage the energy consumption. The monitoring and control system, which is in the basis of any SHEMS [4], [5], integrates the Monitoring Devices (MDs) as well as a User Interface (UI). Each MD has the role of measuring the voltage and the current consumed by the respective household appliance, calculating the power and energy consumption and sending this information to a local central device using a wireless Home Area Network (HAN), whereas the UI allows the user to monitor and control the overall monitoring system and the individual household appliances.

The data transmission may be based on a single wireless network technology, such as IEEE 802.11/Wi-Fi [6], [7], Bluetooth [8], IEEE 802.15.4/ZigBee [9][10] or GSM (Global System for Mobile Communications) [11], or may be based on a hybrid network, such as a Bluetooth/Wi-Fi solution [12]. In this case, a gateway is used to perform the conversion of the exchanged data packets between the different protocols.

Regarding the data processing and calculation of electrical quantities, approaches based on distributed calculation and local in-network processing are more efficient in terms of communication overhead and time calculation [13].

Concerning related work in this area. Ahsan et al. [13] discuss the advantages of the distributed processing for home energy management system compared to centralized system. Their application is dedicated for smart grid, so it depends mainly of the electricity operator. The proposed system is tested in a mobile phone (Android app), but they

did not propose a MD hardware. Ertugrul et al. [14] propose a home energy management system for demand-based tariff, where they attempt to reduce the peak demand of the household. They also present the test hardware, but they do not provide information about the measurement accuracy. However, this system may create some inconvenience to the user, because it acts on any appliance without taking in consideration if the user requires its operation later. To avoid this inconvenient, such application should have a user priorities feature to offer the possibility to choose which appliance may be controlled from the application and which one should not be totally controlled.

In [4], the authors present an electricity bill forecasting application for energy management based on an energy monitoring system. The authors assume that the monitoring system should be a learning tool and the user should make less effort to dealing with the system. They also present an application of the monitoring system where they use Wi-Fi for communication.

In [9], Afonso et al. propose a monitoring system to monitor energy consumption and power quality. They present the measurement accuracy of their designed MD as well as the developed UI.

In [13], Ahsan et al. discuss the advantages of the distributed processing in the context of a home energy management system compared to centralized processing. Their application was conceived for smart grid, so it relies mainly on the electricity operator. The proposed system was tested using an Android mobile phone app, but they do not propose a MD hardware.

The proposed SHEMS is mainly adapted for use in the case of payment by consumption slices, as shown into Table 1. In this kind of systems, the payment depends of the number of kilowatt-hours (kWh) consumed over a month. Therefore, as the table shows, when the energy consumption increases, the price per kWh also increases. The final goal is to integrate an energy management algorithm into the SHEMS, which, based on energy consumption, manages the operation of the household appliances.

Table 1. Energy consumption slices per month and their price in Morocco [15].

Energy consumption slices per month	kWh price in Moroccan Dirham (MAD)
0 to 100 kWh	0.9010
101 to 200 kWh	1.0732
201 to 300 kWh	1.1676
301 to 500 kWh	1.3817
>500 kWh	1.5958

We distinguish between appliances with direct contact with the user and indirect contact appliances, which was the problematic noticed in [14]. For the first category, the

system does not act on such appliances, because the user may be using them. For example, in the case of a visual interaction between the user and a television, the system will not turn off the appliance. Nevertheless, it may send a notification for the customer to alert in case of an overuse. On the other hand, for the second category, the system may manage the appliances without notifying the user, for example, turning on/off a refrigerator, since there is no direct interaction between these appliances and the user. The proposed SHEMS is not fully connected to the electricity operator in order to keep some privacy for the customer.

This paper presents the design and the implementation of wireless monitoring and control system of the SHEMS. The rest of the paper is organized as follows. In the second section, we present the architecture of the developed wireless network and provide a description of its main wireless communication technology. The third section presents both the hardware and the software of the developed MDs. The fourth section describes the gateway hardware and its functionalities. In the fifth section, we present experimental results concerning the measurement accuracy and the proper functioning of the monitoring system, as well as the developed Graphical User Interface (GUI) and the respective results. We finalize this paper with the conclusions.

2. Wireless communication network

2.1. Network architecture

The developed wireless monitoring and control system is constituted by several elements connected to each other, which form a wireless communication network. In this manner, the collected data and remote control commands flow across the network between the monitored appliances and the user and/or the algorithm. The connection between the different network devices may be guaranteed by one or more wireless network technologies. For this system, we chose a hybrid solution based on two technologies: IEEE 802.11/Wi-Fi and Bluetooth Low Energy (BLE). The choice of BLE was due to its low cost and low energy consumption, as demonstrated in [16], which discusses the benefits of BLE for this type of applications. On the other hand, the choice of Wi-Fi allows easy access to the collected data using a personal computer or mobile phone inside the local network. In addition, it enables seamless communication with clients and servers located outside the home in a future implementation based on the Internet of Things (IoT) paradigm [17].

Figure 1 shows the network architecture of the proposed wireless monitoring and control system. The network is composed by Monitoring Devices (MD1 to MDn), a BLE/Wi-Fi gateway, a Wi-Fi Access Point (Wi-Fi AP) and client devices. The MDs are connected to the gateway through a BLE network. The developed MD is based on a PSoC 4 BLE module [18], model CY8CKIT-143A, from

Cypress, which acts as communication and data processing unit. This module is based on a 32-bit ARM Cortex-M0 processor core and is compatible with the Bluetooth 4.2 protocol stack. Programmable analog front-ends are used for data acquisition and a Real Time Clock (RTC) is used for timing requirements.

As shown on Figure 1, the user can access the data and control the MDs through the gateway using a computer or mobile phone. The connection between the client devices and the gateway is provided by a Wi-Fi network using the Wi-Fi AP. The gateway hardware is based on a Raspberry Pi 3. This component is used to ensure the connection with all other devices of the wireless monitoring and control system, presenting itself as a local central device. The gateway is also used to perform calculations on the collected data and to store them.

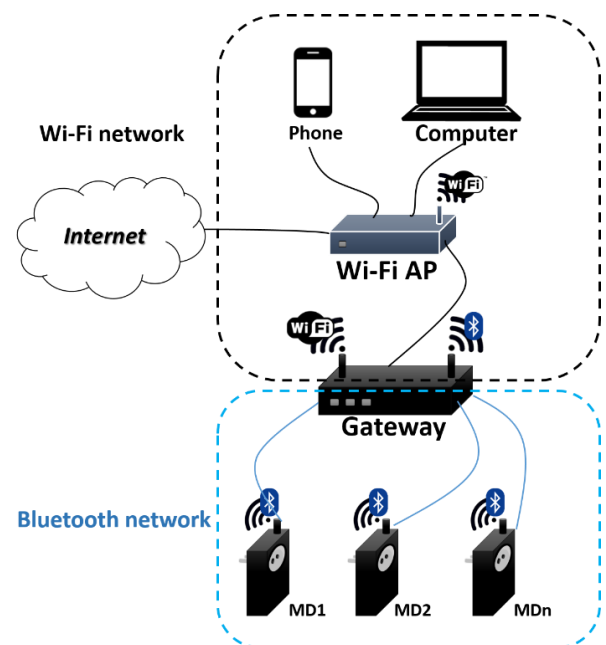

Figure 1. Architecture of the developed wireless monitoring and control network.

2.2. BLE overview

Physical layer

BLE is a communication technology that operates in the 2.4 GHz Industrial, Scientific and Medical (ISM) band using 40 channels spaced out 2 MHz apart. BLE uses frequency hopping, which is a robust mechanism to avoid interference. The BLE over-the-air data rate is 1 Mbit/s and uses Gaussian Frequency-Shift Keying (GFSK) modulation. As shown in Figure 2, BLE uses three advertising channels (channel 37, 38 and 39), which allow for the device discovery. After discovering and connecting, the other 37 channels are used for data transmission. The advertising channels are allocated in different parts of the

spectrum to provide immunity against interference from IEEE 802.11/Wi-Fi networks.

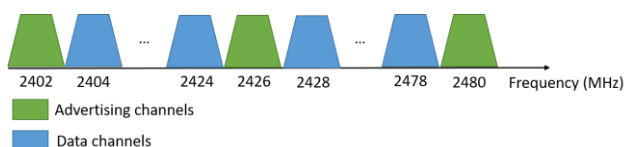

Figure 2. BLE radio frequency channels.

BLE Stack

Figure 3 shows the BLE protocol stack. The protocol stack defines two parts: The controller and the host. The controller includes the physical layer, which is responsible for packet transmission and reception over-the-air, and the link layer, which is responsible for advertising and scanning, as well as the creation and maintenance of connections. The BLE stack is also responsible timing management and queueing of incoming and outgoing packets. The controller communicates with the host through the Host-Controller Interface (HCI).

The host handles the upper protocol layers, including, among others, the Logical Link Control and Adaptation Protocol (L2CAP), the Generic Access Profile (GAP), the Generic Attribute profile (GATT) and the application layer. The L2CAP layer is responsible for data services to the upper level layers, for multiplexing and segmenting packets into fragments for the controller and for reassembling packets from the controller before sending data to the upper level layers. The GAP layer defines generic procedures that are used in the pairing and linking of the devices. The GAP layer is responsible for different Bluetooth modes (advertising, scanning, connect, etc.). The GAP device roles are GAP peripheral and GAP central. In the first one, the device advertises its presence, waits for scan requests and accepts connections from GAP central devices. In the second role, the device scans for advertisements from GAP peripheral and starts the connection procedure.

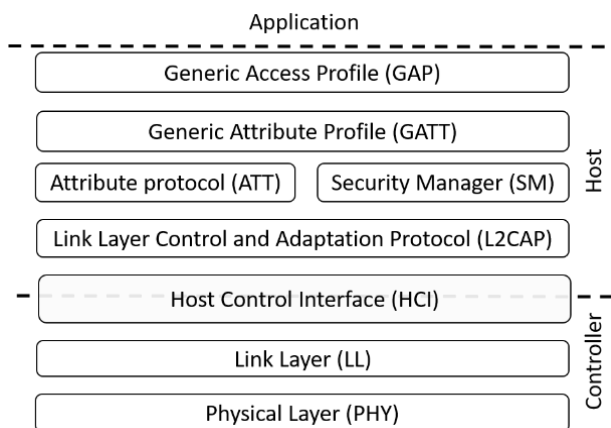

Figure 3. BLE protocol stack.

Profiles, Services and Characteristics

To guarantee the application level layer interoperability between devices, the BLE uses profiles (Figure 4). Two devices should define the same profile to be able to communicate. A profile is a collection of services, and a service is composed of one or more related characteristics that define a function of the device. The Bluetooth SIG (Special Interest Group) offers a set of predefined services [19]. The BLE profile defines the required GATT roles and the GATT services to be supported by the devices. There are two GATT roles: server and client. The first one corresponds to the device that contains data or state to be sent. The second one corresponds to the device that receives data from the GATT server or configures its state. In the monitoring system, a customized profile is used which integrates the Generic Access service, the Generic Attribute service, and two customized services called Electrical Measurement (EM) service and Monitoring Device Control (MDC) service. The EM service contains different characteristics related to the measurements, such as Voltage characteristic, Current characteristic, PowerAVG characteristic, PowerFact characteristic and Energy characteristic. The MDC service contains the control characteristics.

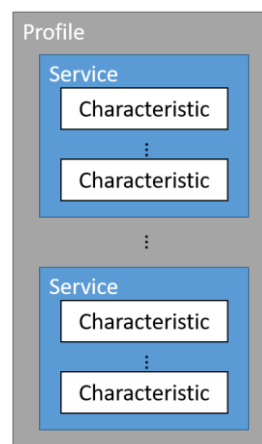

Figure 4. BLE data hierarchy.

3. Monitoring device development

3.1. Developed monitoring device hardware

The developed MD is shown in Figure 5 as a block diagram. It contains voltage and current sensors, signal conditioners and the communication and processing unit, as well as a relay to control the turning on/off of the appliance. The instantaneous voltage and the instantaneous current are measured and thus the power and the energy are calculated. The MD is developed for a single-phase 230 V/50 Hz line.

In Figure 6 and Figure 7, the MD board and its power supply board are presented, respectively. Referring to Figure 6, for the voltage chain, a voltage divider based on

resistors is used as sensor. The output-input ratio is 0.00057. The voltage sensor is followed by the AMC1100 isolation amplifier. This component ensures isolation between the grid and the processing core to secure from high voltage. We added a signal conditioner based on operational amplifier (Figure 8) to provide an offset in such a way to have just a positive signal, because the AMC1100 differential output voltage contains a negative part, but the Analog-to-Digital Converter (ADC) of the processing unit accepts only positive signals.

We used the TA12-100 current transformer as a sensor for the current chain. This component is characterized by a current ratio of 1000:1 and 1% accuracy [20]. We placed in its output a resistor with a value of 220 Ω in such a way to have a maximum voltage equal to 1.5 V for the maximum current. We added also a fixed offset voltage on one of the output terminals of the current sensor (Figure 9) to allow the reading of the negative part of the current signal.

The sampling frequency of the integrated ADC of the processing unit is 5000 samples per second. We note that the Shannon sampling criterion is widely respected. The electrical quantities computation is done in software inside the communication and processing unit, as explained in the subsection.

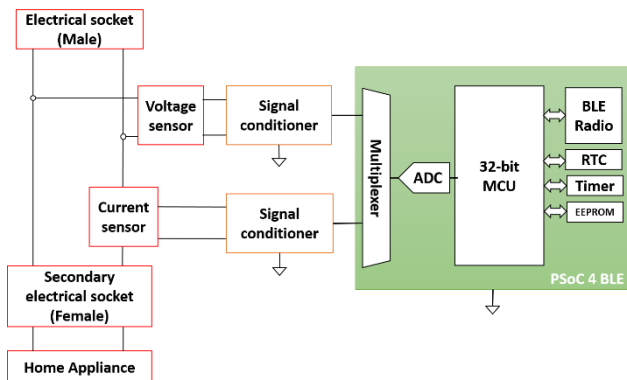

Figure 5. Monitoring device block diagram.

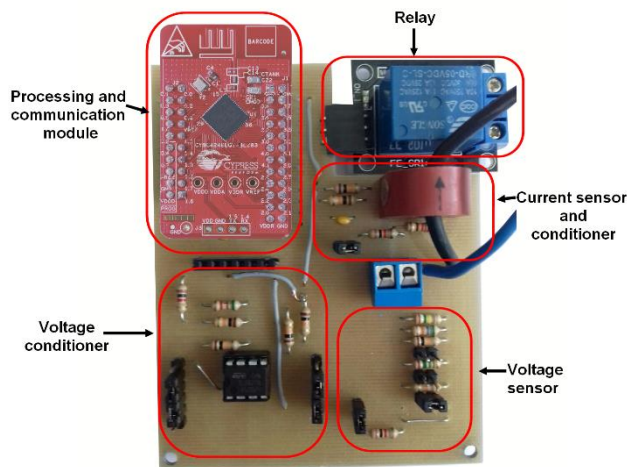

Figure 6. Monitoring device circuit board.

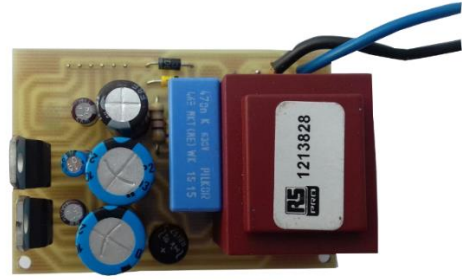

Figure 7. Monitoring device power supply.

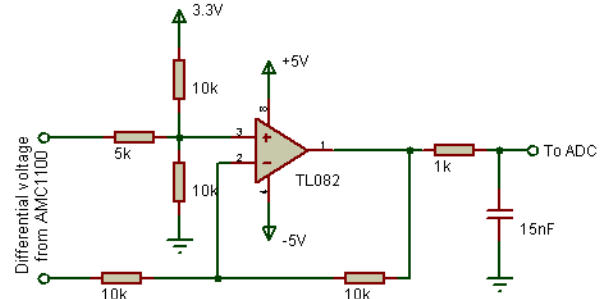

Figure 8. Voltage conditioner circuit.

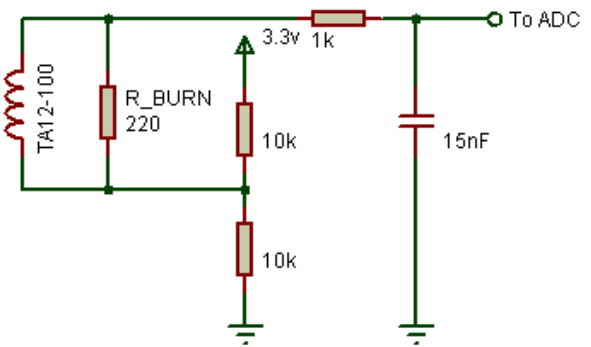

Figure 9. Current measurement and conditioner circuit.

3.2. Software computation and system calibration

After the end of each conversion, the ADC informs the microprocessor through an interrupt that new instantaneous values of the current and the voltage are stored into the corresponding registers. Because the interrupt function should execute the minimum amount of instructions, we use a flag to inform that there is new data to be processed. Into the application task, we calculate the instantaneous voltage, the instantaneous current and the instantaneous power using Eqs. 1, 2 and 3, respectively.

$$v = G_v(k_v \cdot V_{REG} + V_{DCOFF})V_{REF}, \tag{1}$$

where G_v is the voltage gain used to calibrate the voltage chain gain, k_v is a coefficient used to convert the value of the ADC register into a real value (equal to $\frac{1}{ADC\ resolution}$), V_{REG} is the numerical value of the voltage stored into the corresponding register, V_{DCOFF} is the voltage offset used to

calibrate the offset into the voltage chain, if exists, and V_{REF} is the voltage reference.

$$i = G_i(k_i \cdot I_{REG} + I_{DCOFF})I_{REF}, \quad (2)$$

where each term is the same as the voltage equation, except that it is used for the current chain.

$$p = v \cdot i \quad (3)$$

In the application task function (infinite loop), we define a Low Sampling Rate (LSR) which corresponds to 5000 samples of instantaneous values and corresponds to a time interval of one second. For each LSR we calculate the RMS (Root Mean Square) values, active power, energy and other quantities by using the equations presented into Table 2, where N is the number of samples in one LSR and E_i and E_{i-1} correspond to the present energy value and the previous energy value respectively. The term $\frac{P_{AVG_i}}{N_s}$ corresponds to the energy consumed in the last LSR, where $N_s = \frac{3600}{LSR}$. In this case, the energy unit is Wh.

Table 2. Expressions used to calculate the electrical quantities.

Electrical quantity	Formula
RMS voltage	$V_{RMS} = \sqrt{\frac{1}{N} \sum_{i=1}^N v_i^2}$
RMS current	$I_{RMS} = \sqrt{\frac{1}{N} \sum_{i=1}^N i_i^2}$
Average power	$P_{AVG} = \frac{1}{N} \sum_{i=1}^N p_i$
Power factor	$PF = \frac{P_{AVG}}{V_{RMS} \cdot I_{RMS}}$
Energy	$E_i = E_{i-1} + \frac{P_{AVG_i}}{N_s}$

To eliminate the errors due to tolerance values of components such as the resistors used in the amplifiers and ADC offset circuits, the system should be calibrated to allow the system to achieve the required accuracy. The calibration process could be performed analogically or numerically. In our system, we use the numerical methodology to avoid hardware complications. Since the measurement chains are linear, to correct the measurement we have to calibrate the system for just one point of the load.

The DC offset is eliminated using these steps:

- (i) Connecting the input measurement system to the ground.
- (ii) Initializing the gain variable to 1.

- (iii) Measuring several values of the instantaneous voltage and the instantaneous current.
- (iv) Calculating the average values of the voltage and the current.
- (v) Multiplying the found values by -1.
- (vi) Storing the final values into the corresponding variables.

The gain is calibrated using the following steps:

- (i) Applying a reference signal (220 V and 5 A).
- (ii) Calculating several RMS values of the voltage and the current.
- (iii) Correcting the gain by using the Eq. 4.

$$G_x = \frac{\text{Reference value}}{\text{The average of the measured values}}, \quad (4)$$

where x can be v for the voltage gain or i for the current gain.

- (iv) Storing the values of the calculated gains into the corresponding variables, as well as into the EEPROM to avoid a system recalibration.

4. Gateway development

4.1. Gateway hardware

In our monitoring system, we opted to use a Raspberry Pi 3 as gateway. This board presents an interesting set of features to facilitate the development of such systems. It is characterized by a powerful Broadcom BCM2837 System-on-Chip (SoC), which integrates a quad-core ARM Cortex A53, a 1 GB RAM, integrated Bluetooth Low Energy and IEEE 802.11n wireless network support, General Purpose Input Output (GPIO), as well as other data interfaces. These characteristics are sufficient to build the required gateway.

4.2. Gateway functionalities

BLE communication

The gateway integrates the BLE protocol stack, which allows the communication with the MDs. To collect data, we wrote scripts, based on Python language, that run as services. With these scripts, every 5 minutes the gateway, acting as GATT client, establishes a BLE connection with a MD, notifies it to update its characteristics, and starts reading the device characteristics.

Figure 10 shows the communication between the gateway and the MD. We note that the advertising is used just the first time to add the device to the network. After that, the gateway uses the saved bonding information to start a connection with the MDs. We note also that Figure 11 is simplified, that is, not all events are shown.

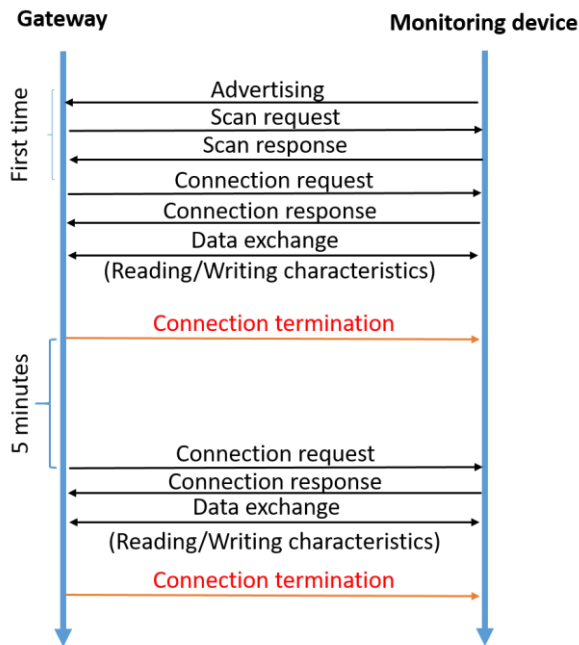

Figure 10. BLE packets exchange between the gateway and the monitoring device.

Wi-Fi communication

The Wi-Fi communication is used between the gateway and client device through the Wi-Fi AP. We use this communication for two needs. The first need is to forward control commands. For this purpose, we use a script acting as a server. In this case, the user interface has a role of client that send requests for the server, and basing on the requested data, the gateway forwards the commands to the corresponding MD. The second need is for the client device to access data consumption stored in the gateway. For this purpose, the user interface is programmed to connect to a SQL (Structured Query Language) database into which the collected data is stored.

Data processing

Local in-network processing and distributed calculation are more efficient in terms of communication overhead and time calculation. In our system, we choose to split data processing between the MDs and the local central device (gateway), to not put all the pressure on the MD processor, which performs a light calculation of RMS voltage and RMS current values and average power, as well as accumulating the energy consumption. In the local central device, on the other hand, we perform robust calculation and data processing of energy consumption for all MDs and during the whole period, as well as the generation of energy consumption statistics.

Data storage

We implemented a SQL database in the gateways to store the energy consumption values and other information, such as overvoltage values and time, overcurrent values and time, etc. We chose to keep information into the gateway,

because in general cases the user could turn off the client device (personal computer or mobile phone), which means that data would be lost because the connection could not be established.

5. Experimental results and discussion

5.1. Measurement accuracy

To evaluate the performance of the developed MD we made tests of the measurement accuracy. We performed accuracy tests for the RMS current and the RMS voltage. According to [21], the RMS voltage value may vary between 0.8 Vref and 1.15 Vref. Therefore, we tested our system in the range of [176 V - 253 V], knowing that the reference voltage is 220 V. We tested the RMS current accuracy for the full-scale input range, which corresponds to the range [0 A - 5 A]. In both cases, the measured values were compared with the values provided by an accurate power measurement device. The relative error of measurement is calculated with Eq. 5:

$$Error (\%) = \frac{Measured\ value - reference\ value}{reference\ value} \times 100 \quad (5)$$

The results from the measurement accuracy tests are shown in Figure 11 and Figure 12. Figure 11 presents the voltage error of the measurements performed by the developed MD. The maximum relative error registered is below 0.2%. Likewise, Figure 12 presents the current error. The maximum relative error seen is below 1% for RMS current values below 0.5 A, and it does not exceed 0.5% for the other values.

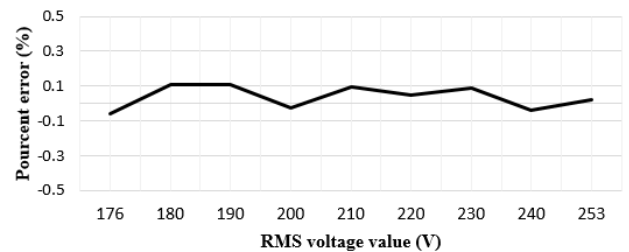

Figure 11. Voltage measurement error.

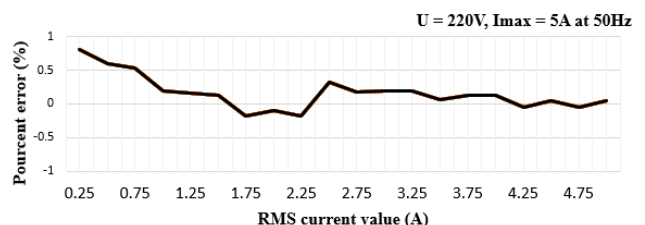

Figure 12. Current measurement error.

5.2. User interface

To complete the development of the wireless monitoring and control system, we created a Graphical User Interface (GUI), shown in Figure 13, for the customer to be able to monitor and control the household appliances. This GUI was developed using Java 8 for the processing part and JavaFx to create the user-friendly interfaces. It allows the user to add new MDs to the monitoring system network, configure, edit or delete them. The GUI includes a panel to visualize the daily power consumption, as well as the energy consumption per month and per year, as shown in Figure 14 and Figure 15. Furthermore, as shown in all the figures, a set of actions are made available to activate or disable a MD, to turn on/off a household appliance and to schedule a turning on/off of an appliance. The user is also able to visualize the real time power consumption information of his household appliances (Figure 16). The example presented in the figures is for a test load of theoretical current equal to 0.65 A. The tests were performed with this load starting at 10:25 AM. After one hour, we added another load that consumes 2.5 A. Later, we increased the current consumption by incrementing the second load.

6. Conclusions

In this paper, we proposed a wireless monitoring and control system that allows residential customers of electrical operator services to monitor and control the individual energy consumption of a set of household appliances. This monitoring system forms the basis of the Smart Home Energy Management System (SHEMS). The

developed system offers to the client a helpful tool to get detailed knowledge of his/her energy consumption and thus the possibility to save energy and reduce his electricity bill.

The presented monitoring system contains a set of components connected to each other, which are: the MDs, the gateway and the client devices. The gateway is located between the MDs and client devices. It is connected through the BLE to the MDs, and thus, collects data and sends commands through this connection. The gateway is also connected to the client devices using a Wi-Fi network.

The performance of the developed MD was evaluated through experimental tests. We obtained, for the voltage measurements, errors below 0.2%, and for the current measurements, the errors were below 0.5%. The accuracy tests for the MDs comply with the recommended norms [22].

To complete our system, we developed a user interface for the customer to be able to monitor and control the MDs.

Besides application scenario described in this paper, the developed hybrid wireless network may be easily extended to other applications in the context of the smart home, which may share the same communication infrastructure, such as monitoring and control of the lighting, heating or security systems, through the connection of the respective sensors and actuators to the PSoC 4 BLE modules.

As future work, we intend to implement a residential energy management algorithm, to manage the energy consumption of the electrical appliances and to give to the user a robust tool to control and reduce his overall energy consumption.

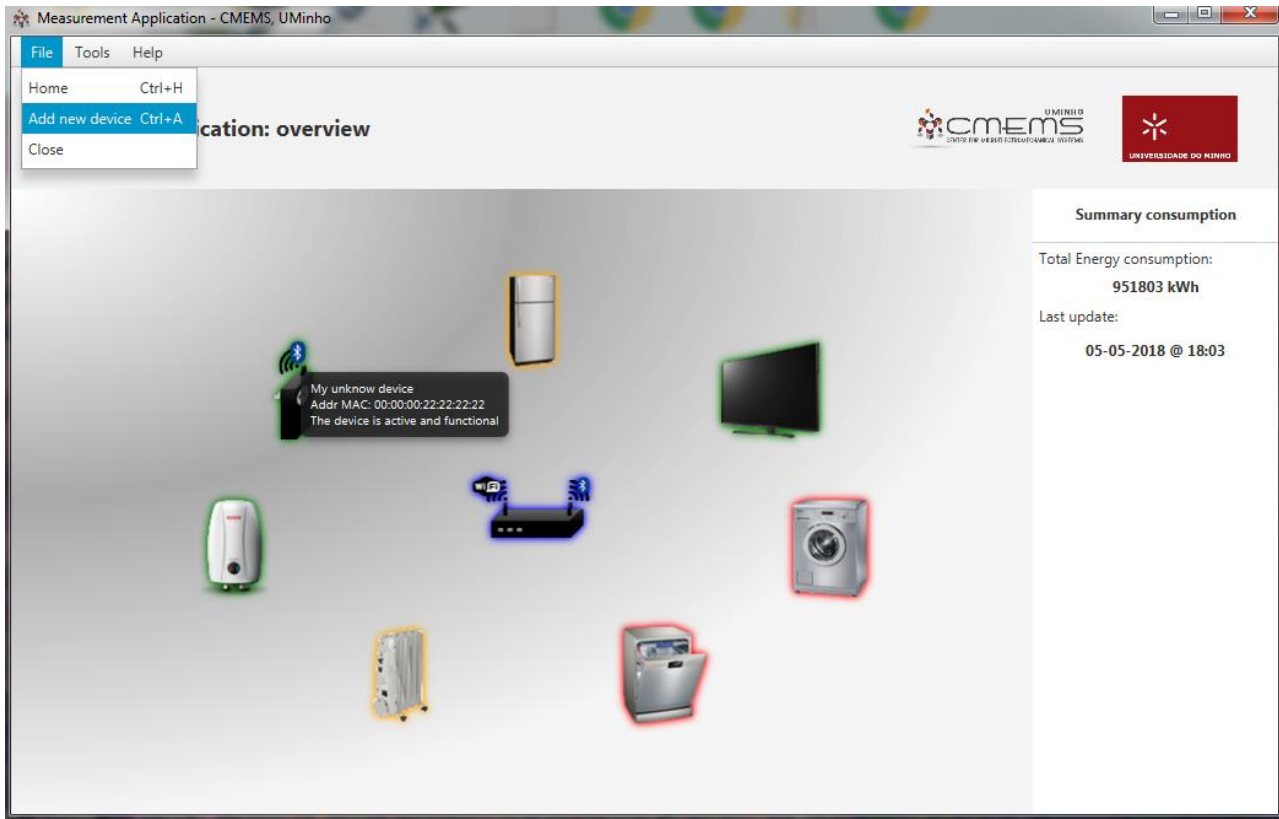

Figure 13. Home screen of the developed GUI.

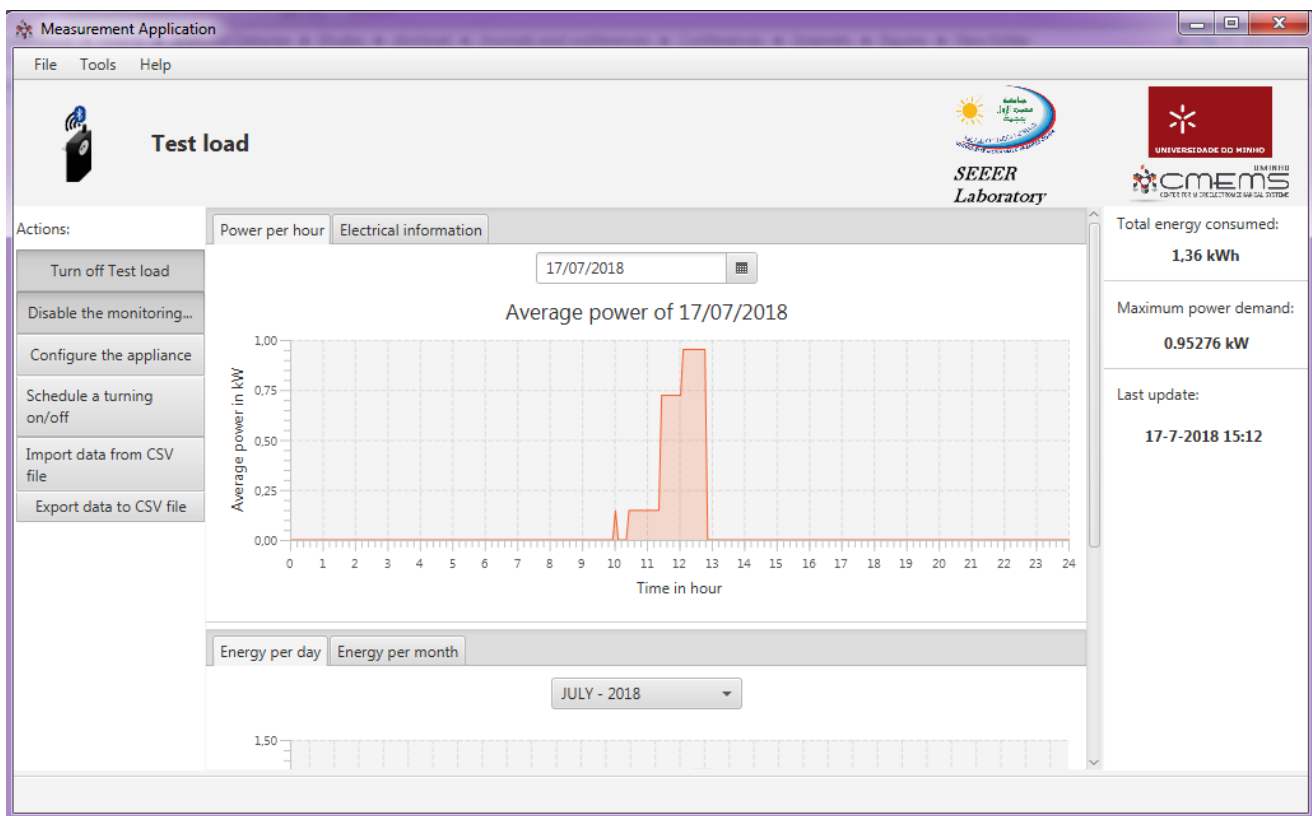

Figure 14. Example of power consumption chart provided by the GUI.

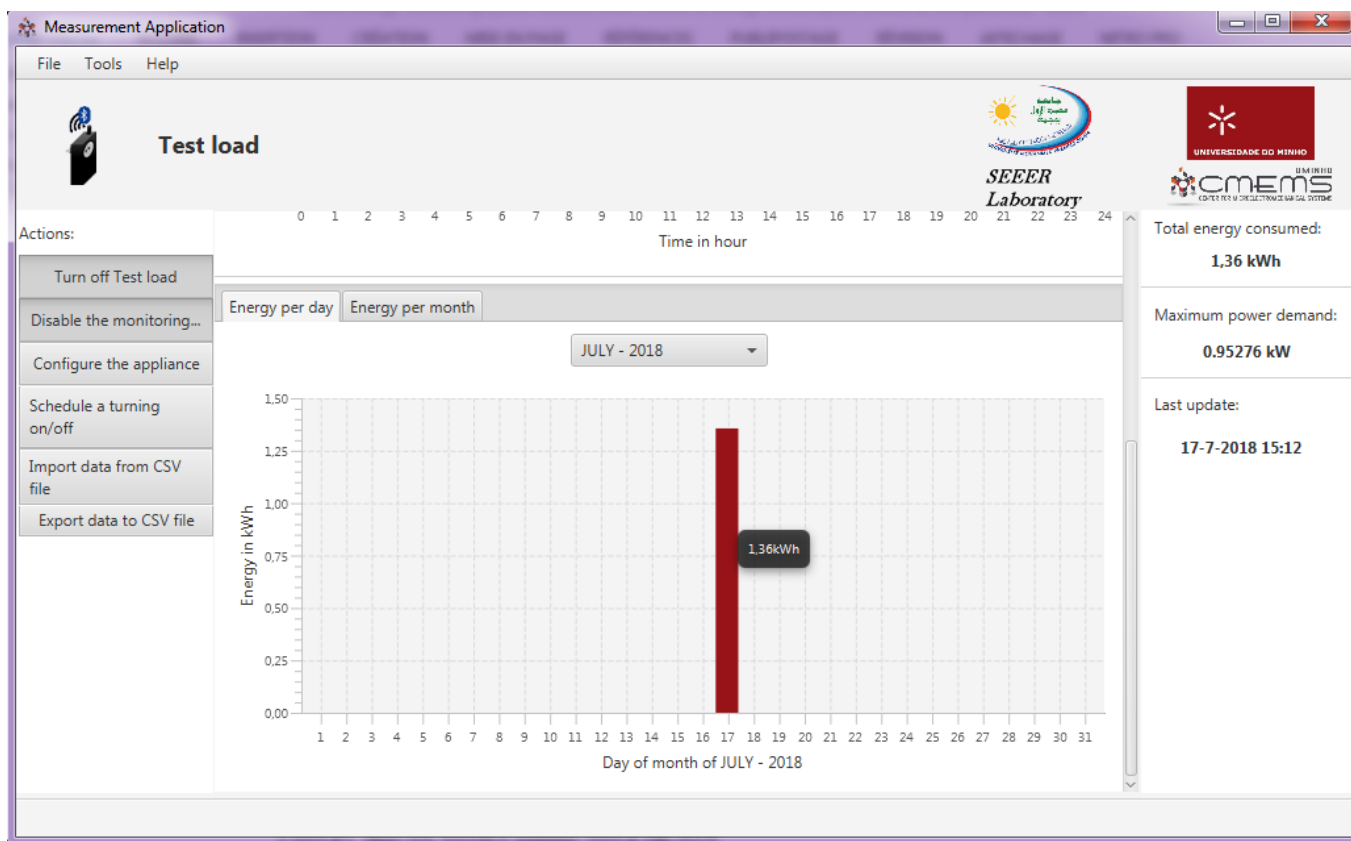

Figure 15. Example of energy consumption chart provided by the GUI.

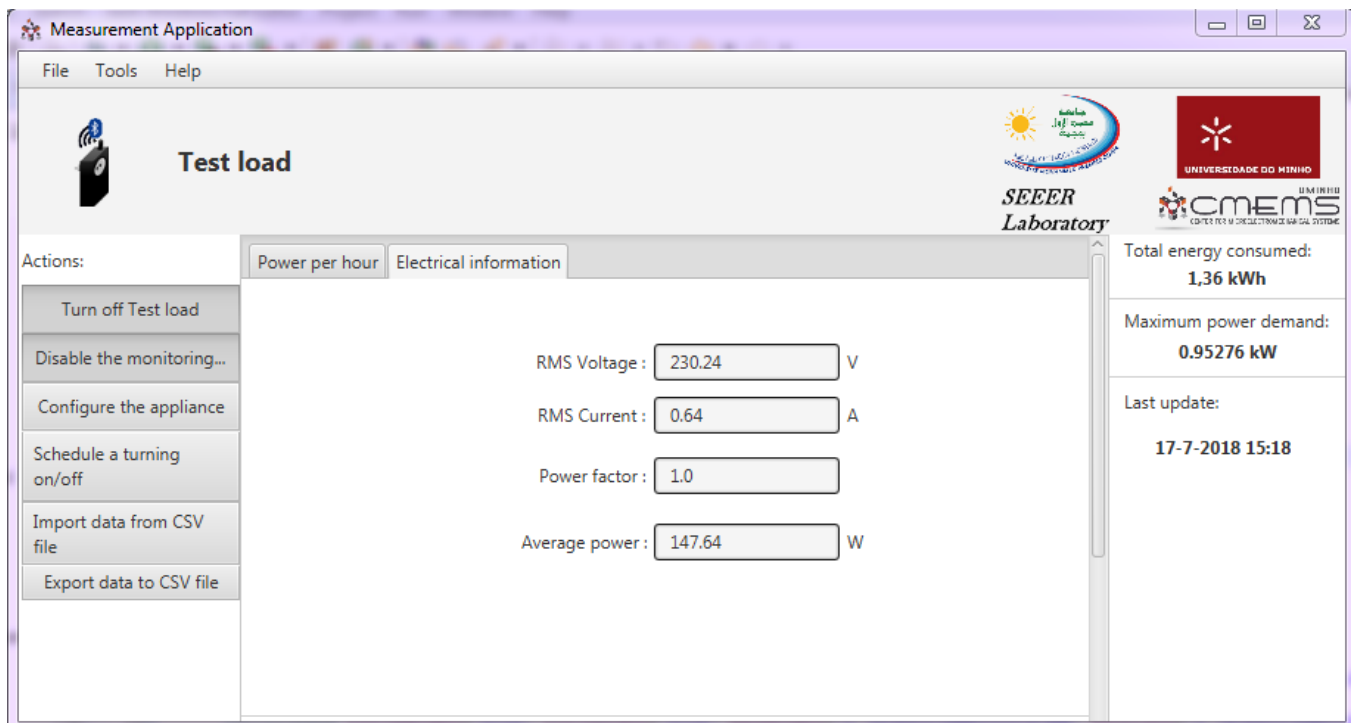

Figure 16. Example of real time electrical information provided by the GUI.

Acknowledgements.

This work is supported by FCT with the reference project UID/EEA/04436/2019.

References

- [1] R. R. Mohassel, A. Fung, F. Mohammadi, and K. Raahemifar, "A survey on Advanced Metering Infrastructure," *Int. J. Electr. Power Energy Syst.*, vol. 63, pp. 473–484, 2014.
- [2] Z. Jebroni, H. Chadli, E. Chadli, and B. Tidhaf, "Remote calibration system of a smart electrical energy meter," *J. Electr. Syst.*, vol. 13, no. 4, pp. 806–823, 2017.
- [3] Z. Jebroni, H. Chadli, B. Tidhaf, A. Benlghazi, and A. Tahani, "Gain Correction and Phase Compensation of a Smart Electrical Energy Meter," in *2016 International Conference on Engineering & MIS (ICEMIS)*, 2016.
- [4] C. Chupong and B. Plangklang, "Electricity bill forecasting application by home energy monitoring system," in *2017 International Electrical Engineering Congress, iEECON 2017*, 2017.
- [5] Z. Jebroni, J. A. Afonso, and B. Tidhaf, "Home Energy Monitoring System Towards Smart Control of Energy Consumption," in *Green Energy and Networking*, 2019, vol. 269, pp. 40–53.
- [6] A. Sharma, A. Verma, and M. Bhalla, "WiFi home energy monitoring system," in *2016 International Conference on Information Technology, InCITe 2016 - The Next Generation IT Summit on the Theme - Internet of Things: Connect your Worlds*, 2016, pp. 59–61.
- [7] B. W. Guido R. Hiertz, Dee Denteneer, Lothar Stibor, Yunpeng Zang, Xavier Pérez Costa, "The IEEE 802 . 11 Universe," vol. 48, no. 6, pp. 62–70, 2010.
- [8] Bluetooth Special Interest Group (SIG), Specification of the Bluetooth system. Master table of contents & compliance requirements. Version 5.0, December 2016..
- [9] J. A. Afonso, F. Rodrigues, P. Pereira, H. Gonçalves, and J. L. Afonso, "Wireless Monitoring and Management of Energy Consumption and Power Quality Events," in *Proceedings of the World Congress on Engineering*, 2015, vol. I.
- [10] P. Baronti, P. Pillai, V. W. C. Chook, S. Chessa, A. Gotta, and Y. F. Hu, "Wireless sensor networks: A survey on the state of the art and the 802.15.4 and ZigBee standards," *Comput. Commun.*, vol. 30, pp. 1655–1695, 2007.
- [11] A. Rashdi, R. Malik, S. Rashid, A. Ajmal, and S. Sadiq, "Remote Energy Monitoring, Profiling and Control Through GSM Network," in *Arabian Journal for Science and Engineering*, 2012, pp. 184–188.
- [12] Y. Bikrat, D. Moussaid, A. Benali, and A. Benlghazi, "Electronic and Computer System for Monitoring a Photoltaic Station," in *2018 International Conference on Intelligent Systems and Computer Vision (ISCV)*, 2018.
- [13] U. Ahsan and A. Bais, "Distributed Smart Home Architecture for Data Handling in Smart Grid Architecture distribuée d'une maison intelligente pour la gestion des données dans un réseau intelligent," *Can. J. Electr. Comput. Eng.*, vol. 41, no. 1, pp. 17–27, 2018.
- [14] N. Ertugrul, C. E. McDonald, and J. Makestas, "Home energy management system for demand-based tariff towards smart appliances in smart grids," in *Proceedings of the International Conference on Power Electronics and Drive Systems*, 2017, pp. 511–517.
- [15] Electricity tariffs. [Online]. Available: <http://www.one.org.ma/FR/pages/interne.asp?esp=1&id1=3&id2=113&t2=1>.
- [16] J. A. Afonso, A. J. F. Maio, and R. Simoes, "Performance Evaluation of Bluetooth Low Energy for High Data Rate Body Area Networks," in *Wireless Personal Communications*, 2016, vol. 90, no. 1, pp. 121–141.
- [17] A. Al-fuqaha, M. Guizani, M. Mohammadi, M. Aledhari, and M. Ayyash, "Internet of Things: A Survey on Enabling Technologies," *Commun. Surv. Tutorials, IEEE*, vol. 17, no. 4, pp. 2347–2376, 2015.
- [18] Cypress Semiconductor, "CY8CKIT-042-BLE-A Bluetooth® Low Energy 4.2 Compliant Pioneer Kit." [Online]. Available: <https://www.cypress.com/documentation/development-kitsboards/cy8ckit-042-ble-bluetooth-low-energy-42-compliant-pioneer-kit>.
- [19] Bluetooth Special Interest Group (SIG), "GATT Services." [Online]. Available: <https://www.bluetooth.com/specifications/gatt/services>.
- [20] TA12-100 datasheet. [Online]. Available: <http://en.yhdc.com/product1371.html?productId=492>
- [21] ONEE-BE, "Technical specification - electronics energy meter for low voltage customers," 2014.
- [22] International Electrotechnical Commission (IEC, "IEC 62053-21 – Electricity metering equipment (a.c.) – Part 21: Static meters for active energy (classes 1 and 2)," 2003.