

Power Quality Enhancement in PV integrated System Using GSA-FOPID CC-VSI Controller

B. Srikanth Goud¹, CH. Naga Sai Kalyan², D. Krishna³, B. Nagi Reddy⁴, Mohit Bajaj^{5,6,7}, Subhashree Choudhury⁸ and Swati Shukla⁹, *

^{1,3} Department of EEE, Anurag University, Hyderabad, 500088, India

² Department of EEE, Vasireddy Venkatadri Institute of Technology, Guntur, 522508, India

⁴ Department of EEE, Vignana Bharathi Institute of Technology, Hyderabad, India

⁵ Department of Electrical Engineering, Graphic Era (Deemed to be University), Dehradun, 248002, India

⁶ Department of Electrical Engineering, Graphic Era Hill University, Dehradun, 248002, India

⁷ Applied Science Research Center, Applied Science Private University, Amman-11937, Jordan

⁸ Department of EEE, Siksha 'O' Anusandhan (Deemed to be University), Bhubaneswar, 751030, India

⁹ VIT-AP University, Amaravati, Andhra Pradesh, India

Abstract

Over the past ten years, a lot of effort has been made to promote the broad adoption of renewable energy. This has led to a push to generate electricity from renewable resources like wind and solar. However, power quality (PQ) concerns may arise from incorporating these renewable energy sources into the system. Researchers have so been working on new methods for addressing PQ problems. Most of the methods described in the literature deal only with one particular kind of PQ problem. However, PQ concerns have gotten increasingly serious owing to the extensive integration of various renewables into the distribution system. In this research, we provide a formalisation of the PQ problem as an optimisation problem and suggest an implementation of the Genetic Search Algorithm (GSA) to address it. Harmonic distortion, power loss, and voltage are used as metrics for success. Simulation in MATLAB/Simulink is used to analyse the proposed system and compare it to a standard PI controller. When combining renewables to Grid Connected System, the proposed GSA-based FOPID control system efficiently reduces the impact of PQ concerns and keeps the output power where it needs to be.

Keywords: GSA, FOPID controller, VSI

Received on 08 July 2023, accepted on 02 September 2023, published on 25 September 2023

Copyright © 2023 B. Srikanth Goud *et al.*, licensed to EAI. This is an open access article distributed under the terms of the [CC BY-NC-SA 4.0](https://creativecommons.org/licenses/by-nc-sa/4.0/), which permits copying, redistributing, remixing, transformation, and building upon the material in any medium so long as the original work is properly cited.

doi: 10.4108/eetsis.3974

1. Introduction

Due to technological developments and rising environmental concerns about conventional energy sources, renewable energy resources, especially distributed generators, have acquired considerable relevance [1]. Since renewable energy sources like solar and wind power, as well as storage technologies like batteries, are playing a bigger part in

fulfilling today's power needs, various optimisation approaches have been created to allow for more nuanced regulation of power electronics and control technology [2]. Distributed generation's growing significance may be attributed to the fact that it overcomes the shortcomings of traditional energy sources by supplying commercial loads that demand constant monitoring with more productive, higher-quality, and reliable electricity [3]. To meet the demands of a developing economy and population, distribution generators increasingly rely on non-conventional sources.

It is first fed to the DC link of the grid connected inverter with the help of GSA technique to transfer the power to the grid. Even if the load is linked at a non-linear or unbalanced

*Corresponding author: Email: swati.shukla@vitap.ac.in

common coupling point, the suggested method may adjust for harmonics and unbalances, regardless of the state of the supply voltage [4-5]. We want to correct for load wattage power, current harmonics, and current imbalance with respect to the actual power injection from DG sources to the grid and grid-interfacing inverters.

Recent literature has seen an uptick in studies focused on optimising the PQ of hybrid renewable energy systems linked to the grid. Our solution applies an estimated search algorithm while integrating wind, PV, and batteries into the HRES grid-connected system, a breakthrough technology that lowers PQ worries and retains output power where it is required. Seven test cases are used to verify the proposed model's performance; each instance has a unique combination of wind, PV, and battery connections, as well as a unique set of loads [6-7]. The analysis demonstrates the viability of the suggested method.

This paper makes the following contributions: Section II discusses CC-VSI, control structure in section III, Section IV discusses the GSA technique, Section V discusses the proposed FOPID controller, Section VI describes results and discussions, and Section VII concludes.

2. CC-VSI Control Structure

Figure.1 shows the system circuit that was designed for this system. A photovoltaic (PV) array and a wind turbine are part of a Distribution Generation system that interfaces with the grid via a CC-VSI and a DC-link capacitor [8]. With the aid of the Extended Search Algorithm, the PV and wind sources are utilised to their full potential, and a reference DC-link voltage is produced. When solar power is unavailable, this reference voltage returns to its normal value. The VSI's AC side is connected to an inductive filter, and the DC side is connected to a step-up transformer before being connected to the PCC. The PCC is connected to a non-linear load using an unregulated rectifier. An inverter control is used to minimise harmonics and power factor in the load current and to manage the flow of DG power into the PCC [9-10].

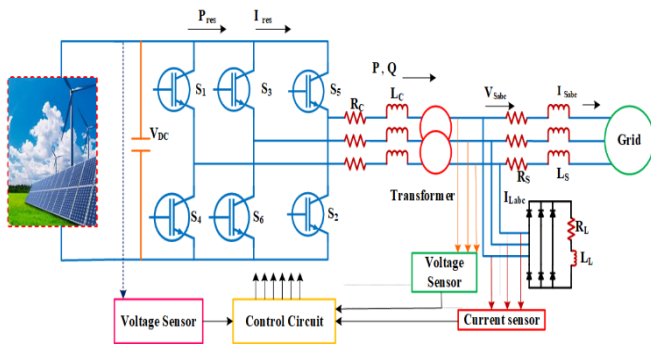

Figure 1. Architecture of the Proposed System

3. Structure of the Control Circuit

A double loop current controller is used to achieve zero steady-state error for delivered currents [11]. It consists of an outer circuit with PI control and an inner circuit with capacitor current control. Figure 2 represents the CC-VSI of the grid-interfacing inverter. The proportional controller enhances stability. The Vsabc's sine and cosine characteristics are derived using a phase-locked loop (PLL) in the circuit's control section. The compensation signal is produced by deriving the unit vector from the PLL signal in cases where the power supply is malfunctioning. A set of n harmonics with $n = \{1, 2, 3, \dots, N\}$. During this instant their current $i_L(t)$ and Voltage $V_s(t)$ can be expressed as:

$$V_s(t) = \begin{bmatrix} V_{s1} \\ V_{s2} \\ V_{s3} \end{bmatrix} = \begin{bmatrix} \sum_{n=1}^N V_{sn1} \sin(n\omega t) \\ \sum_{n=1}^N V_{sn2} \sin(n(\omega t - 120^\circ)) \\ \sum_{n=1}^N V_{sn3} \sin(n(\omega t - 240^\circ)) \end{bmatrix} \quad (1)$$

$$i_L(t) = \begin{bmatrix} i_{L1} \\ i_{L2} \\ i_{L3} \end{bmatrix} = \begin{bmatrix} \sum_{n=1}^N I_{Ln1} \sin(n\omega t - \varphi_{n1}) \\ \sum_{n=1}^N I_{Ln2} \sin(n(\omega t - 120^\circ) - \varphi_{n2}) \\ \sum_{n=1}^N I_{Ln3} \sin(n(\omega t + 120^\circ) - \varphi_{n3}) \end{bmatrix} \quad (2)$$

The $(I_{Ln1}, I_{Ln2}, I_{Ln3})$ Load current peak values, (V_{s1}, V_{s2}, V_{s3}) PCC Voltages peak values, $\varphi_{n1}, \varphi_{n2}, \varphi_{n3}$ are n^{th} order harmonics. The actual power and wattles flowing from the inverter's output to the main theme can be illustrated as,

$$P = \frac{V_s V_c}{X_c} \sin \delta_c = \frac{m_a V_{fc} V}{X_c} \sin \delta_c \quad (3)$$

$$Q = \frac{V_s}{X_c} (V_c \cos \delta_c - V_s) \quad (4)$$

$$Q = \frac{V_s}{X_c (m_a V_{fc} \cos \delta_c - V_c)} \quad (5)$$

Modulation depth of the inverters is m_a , $V_c < \delta_c$ is the inverter output, $V_s < 0$ is the voltage of PCC and inductive filter impedance is $X_c = R_c + j\omega L_c$. P_s is the power transferred by the grid and compensated at unity power factor.

$$P_s = P_L + P_l - P = \frac{3}{2} V_{s1} I_{s1}^* \quad (6)$$

P_l is the loss power, P is the DG power, P_L the load power and I_{s1}^* is a source current term and is as follow,

$$I_{s1}^* = \frac{2P_s}{3V_{s1}} \quad (7)$$

$$u_{s1}(t) = u_a(t) \quad (8)$$

$$u_{s2}(t) = -0.5 u_a(t) + 0.866 u_b(t) \quad (9)$$

$$u_{s3}(t) = -0.5 u_a(t) + 0.866 u_b(t) \quad (10)$$

Where reference currents are $ua(t) = \sin\omega t$ and $ub(t) = \cos\omega t$. The inverter current components and the reference current are fed to the hysteresis controller to minimize the error which are $(\Delta i_{c1}, \Delta i_{c2}, \Delta i_{c3})$, by adjusting the duty ration of the PWM.

$$\Delta i_{c1} = I_{c1}^*(t) - i_{c1} \quad (11)$$

$$\Delta i_{c2} = I_{c2}^*(t) - i_{c2} \quad (12)$$

$$\Delta i_{c3} = I_{c3}^*(t) - i_{c3} \quad (13)$$

In a grid-connected adapter, the hysteresis regulator uses the disparity between the inverter's actual and apparent current to regulate and alter the pulse in both gates actuators. If the hysteresis band width is small, S1 in phase A of the inverter will be on while $\Delta i_{c1} > H_b$ and S4 are off, and if $\Delta i_{c1} < -H_b$, H_b 's large, the opposite will be true. Both legs will experience alternating pulses with the same period.

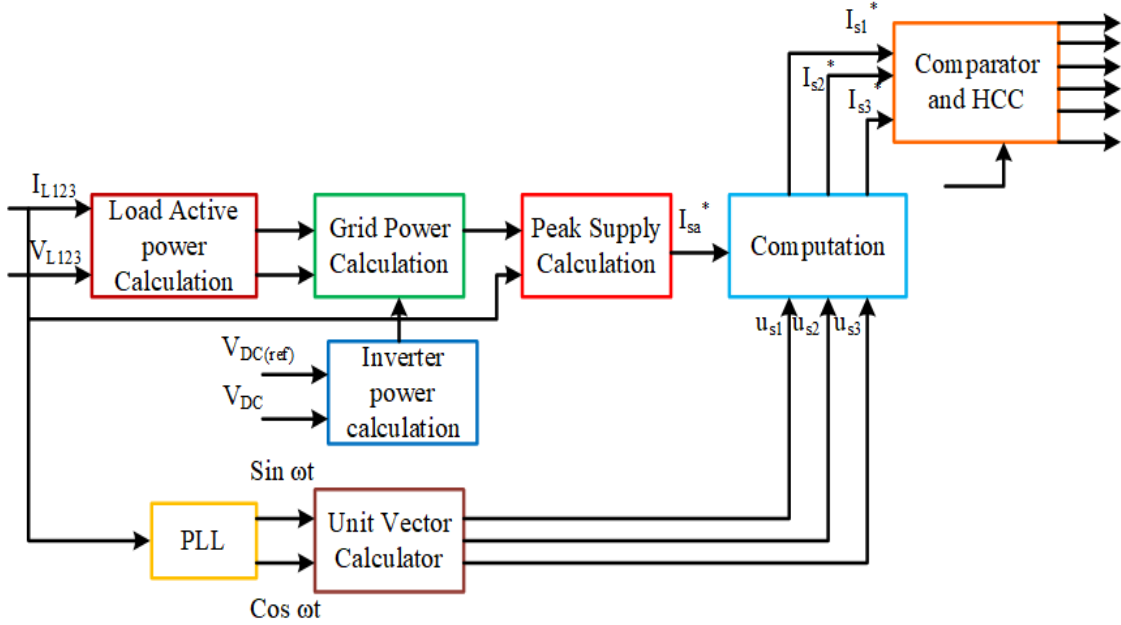

Figure 2. Modeling of Control Circuit

4. Genetic Search Algorithm

The principles of gravity and motion serve as motivation for the meta-heuristic optimisation technique known as the GSA. It may be used to resolve a number of optimisation issues, including those involving the management of power electronics.

One may utilise it to optimise the inverter's control settings, including the modulation index, switching frequency, and reference current, to implement the GSA to a CC-VSI. For optimum inverter performance, the GSA algorithm looks for these parameters' best possible values.

A real-time update of the control strategy based on the current system state and the intended output is one technique to implement the GSA algorithm in a CC-VSI. Improved performance overall, less losses, and increased efficiency can result from this.

The performance and effectiveness of a CC-VSI may be significantly enhanced by using the GSA algorithm, as shown in Figure 3.

5. FOPID Controller

FOPID controllers are an innovative controller type that improve performance in systems with complicated dynamics and uncertainties by using fractional calculus. The FOPID controller may manage the voltage of the distribution network and improve the PQ and dependability of the system in Dynamic Voltage Restorer (DVR) applications.

However, the optimal performance of the FOPID controller is mostly involved on the accurate tuning of its parameters, which can be a challenging task in practice. To overcome this issue, the Gravitational Search Algorithm (GSA) optimization technique can be used to automatically adjust the FOPID controller's parameters and obtain the best possible control performance. Eq(14) represents the FOPID controller modeling. Figure.4 represent FOPID controller structure.

$$u(s) = K_p E(s) + K_i \int E(s) + K_d \text{ddt} E(s) \quad (14)$$

6. FOPID Controller

6.1 Case-I: During starting condition

Figure 5 depicts the PCC voltage, grid current, load current, and inverter output current beginning at time $t = 0$ and continuing for 0.25 seconds. The three-phase PCC voltage and grid current are depicted. Because the grid is meeting the reactive power needs of the load connected there, the PCC voltage and current are initially out of phase. When the DG is turned on at $t = 0.1$ s and there is a 180-degree phase shift between the PCC voltage and the grid current, the excess power from the DG is given to the grid at a unity power factor.

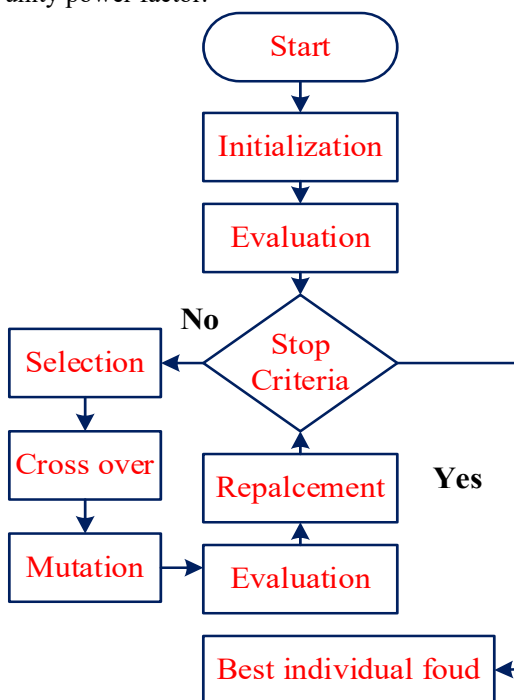

Figure 3. GSA Flow chart

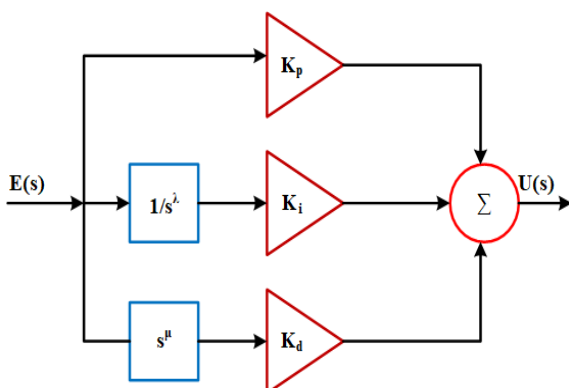

Figure 4. FOPID Controller

6.2 Case-II: Analysis during Non-Linear load condition

The time-varying character of non-linear loads necessitates an examination of the dynamic performance of the system in relation to the fluctuation in load. The load is a three-phase diode rectifier (R), a 10-mH inductor (LL), and a 20-resistor (RL) in series. At time $t = 4.0$ s, a new R-L segment with values $R = 20$ and $L = 5$ mH is added to the load, and it is subsequently removed at time $t = 4.2$ s. As a result, at $t = 4.0$ s, the non-linear load current climbs from 40.26 A to 52 A before decreasing back to 40.26 A at $t = 4.2$ s depicted in Figure. 6

The system, according to the findings, exhibits decent dynamic performance in the face of a rapid shift in the non-linear load.

Figure. 7 represents the active power of the DG, load power and grid power with 72kW, 17kW and 55kW. Figure. 8 represents the reactive power of the DG, load and Grid to be 16.2kVAR, 11.2kVAR and 5Kvar. Table. 1 represents the system parameters and Table. 2 represents the GSA-FOPID controller gains.

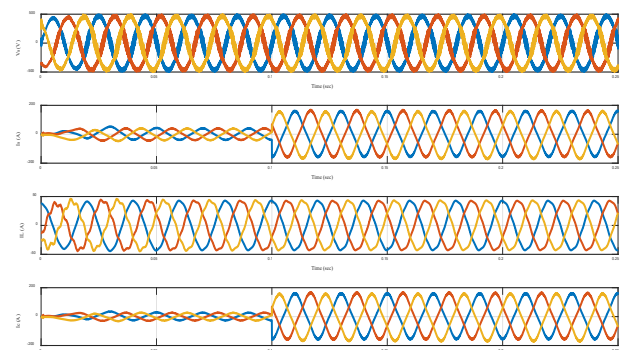

Figure 5. Analysis of V_s , I_s , I_L , I_c during starting condition

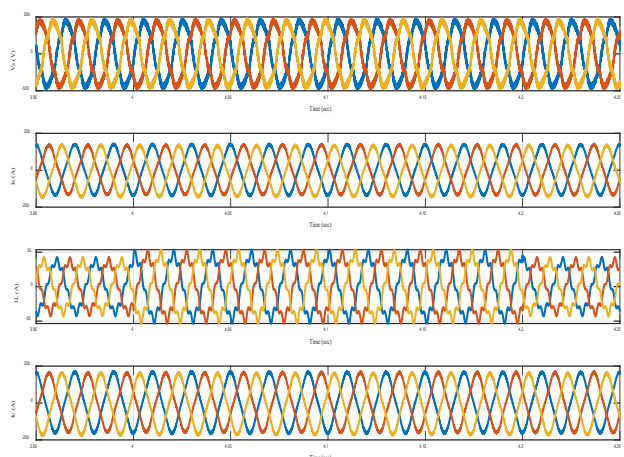

Figure 6. Analysis of V_s , I_s , I_L , I_c during non-linear load condition

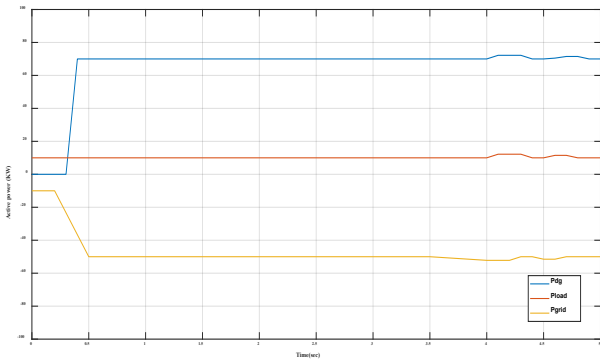

Figure 7. Comparison of Active power of DG, Load and Grid

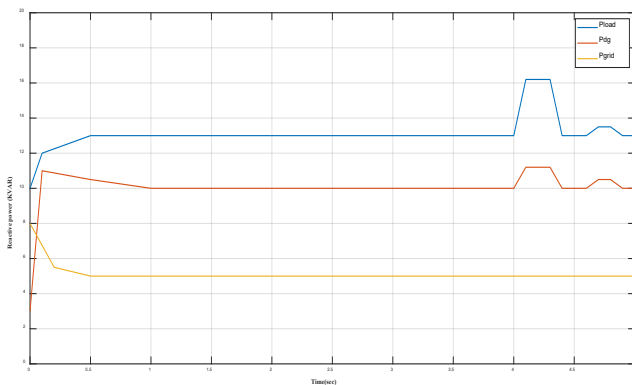

Figure 8. Comparison of Reactive power of DG, Load and Grid

TABLE I. SYSTEM PARAMETERS

Parameter	Value
Source Voltage	550V
Frequency	50Hz
DC Link	600V
Resistance	1Ω
Capacitance	20μF

TABLE II. GSA-FOPID CONTROLLER OPTIMAL GAINS

Parameters	Value
K_P	49.4264
K_I	29.750
K_D	0.3953
Lam	1
Del	0.82

7 Conclusion

This study introduces a novel control mechanism for an existing DG grid-interfacing inverter in order to improve PQ at the PCC without interfering with the regular operation of real power transfer. Rather than installing separate power conditioning devices at the PCC, the proposed method makes use of the grid-interfacing inverter to inject the actual power generated by the RES into the grid. This method efficiently corrects for the imbalanced non-linear load's impact on the PCC's current, harmonics, and reactive power. On the grid side, this results in a balanced, sinusoidal, unity-power-factor current.

References

- [1]. Mohamed Metwally, Yahia M. Esmail, Basiony Shehata, Omar Makram Kamel, Kareem Aboras, Mohit Bajaj, Syed Sabir Hussain Bukhari, "Voltage Quality Enhancement of Low-Voltage Smart Distribution System Using Robust and Optimized DVR Controllers: Application of Harris Hawks Algorithm", *International Transactions on Electrical Energy Systems*, vol. 2022, Article ID 4242996, 18 pages, 2022. <https://doi.org/10.1155/2022/4242996>.
- [2]. Nima Khosravi, Rasoul Baghbanzadeh, Adel Oubelaid, Marcos Tostado-Véliz, Mohit Bajaj, Zineb Hekss, Salwa Echalih, Youcef Belkhier, Mohamad Abou Houran, Kareem M. Aboras, "A novel control approach to improve the stability of hybrid AC/DC microgrids", *Applied Energy*, Volume 344, 2023, 121261, ISSN 0306-2619, <https://doi.org/10.1016/j.apenergy.2023.121261>.
- [3]. Mohit Bajaj, "Design and Simulation of Hybrid DG System Fed Single-Phase Dynamic Voltage Restorer for Smart Grid Application", *Smart Science*, 8:1, 24-38, 2020. DOI: 10.1080/23080477.2020.1748928.
- [4]. T. M. Thamizh Thentral, R. Palanisamy, S. Usha, et.al, "The Improved Unified Power Quality Conditioner with the Modular Multilevel Converter for Power Quality Improvement", *International Transactions on Electrical Energy Systems*, vol. 2022, Article ID 4129314, 15 pages, 2022. <https://doi.org/10.1155/2022/4129314>.
- [5]. M. Bajaj and A. k. Singh, "Designing of a Solar Energy based Single Phase Dynamic Voltage Restorer using Fuzzy Logic Controlled Novel Boost Inverter," 2020 IEEE 9th Power India International Conference (PIICON), Sonapat, India, 2020, pp. 1-6, DOI: 10.1109/PIICON49524.2020.9112965.
- [6]. Subhashree Choudhury, George Tom Varghese, Satyajit Mohanty, et al., "Energy management and power quality improvement of microgrid system through modified water wave optimization, *Energy Reports*, Volume 9, 2023, Pages 6020-6041, ISSN 2352-4847, <https://doi.org/10.1016/j.egy.2023.05.068>.
- [7]. Thanikanti, S. B., Kumar, P., Devakirubakaran, S., Aljafari, B., & Colak, I. (2023). A dynamic mismatch loss mitigation algorithm with dual input dual output converter

- for solar PV systems. *Solar Energy Materials and Solar Cells*, 251, 112163.
- [8]. Goud, B. S., Reddy, C. R., Bajaj, M., Elattar, E. E., & Kamel, S. (2021). Power Quality Improvement Using Distributed Power Flow Controller with BWO-Based FOPID Controller. *Sustainability*, 13(20), 11194.
- [9]. Reddy, B. N., Goud, B. S., Kalyan, S., Naga, C., Balachandran, P. K., Aljafari, B., & Sangeetha, K. (2023). The Design of 2S2L-Based Buck-Boost Converter with a Wide Conversion Range. *International Transactions on Electrical Energy Systems*, 2023
- [10]. Srikanth Goud B, Ch Rami Reddy, CH Naga Sai Kalyan, Ramanjaneya R. Udumula, Mohit Bajaj, Bdereddin Abdul Samad, Mokhtar Shouran, Salah Kamel, "PV/WT Integrated System Using Grey Wolf Optimization Technique for Power Quality Improvement" *Frontiers in Energy Research*, 2022. doi: 10.3389/fenrg.2022.957971.
- [11]. Nima Khosravi, Abdollah Abdolvand, Adel Oubelaid, Yawer Abbas Khan, Mohit Bajaj, Scott Govender, "Improvement of power quality parameters using modulated-unified power quality conditioner and switched-inductor boost converter by the optimization techniques for a hybrid AC/DC microgrid" *Scientific Reports*, 12, 21675, 2022. <https://doi.org/10.1038/s41598-022-26001-8>.