

# Sound Art of Internet of Things Explore: Sound Sensors in the Fusion of Painting and Music

Ling Li<sup>1,\*</sup> and Yuxian Li<sup>2</sup>

<sup>1</sup>School of Conservatory Music Shan Dong University of Art, Jinan 250014, Shandong, China

<sup>2</sup>Jinan Technician College, Jinan 250000, Shandong, China

## Abstract

**INTRODUCTION:** The combination of sound art and Internet of Things (IoT) technology offers new possibilities for artistic creation. With the rapid development of the Internet of Things (IoT), sound sensors have become a powerful tool for capturing environmental sounds. This study aims to explore the application of suitable sensors in the fusion of painting and music by utilizing IoT technology to create more prosperous and interactive artworks for artists.

**OBJECTIVES:** The study's primary purpose is to explore the potential uses of sound sensors in art creation, especially in integrating painting and music. By deeply analyzing the interaction between sound and visual art, the researchers aim to discover new creative possibilities, thus expanding the boundaries of artistic creation.

**METHODS:** The study utilized a comprehensive methodology that included a literature review, field research, and artistic practice. First, the literature on sound art, IoT, and art fusion was extensively reviewed to provide a theoretical foundation for the study. Second, through field research, the researchers collected practical examples of sound sensors applied in the field of art. Finally, through hands-on art creation in the artist's studio, the researchers verified the potential applications of suitable sensors in the fusion of painting and music.

**RESULTS:** The study found that sound sensors have many applications in painting-music fusion. By embedding suitable sensors into painting tools and music devices, artists can capture the sounds of their surroundings and transform them into visual and auditory artistic expressions. Examples from practice demonstrate how this technological innovation can bring a richer, more sensual experience to artistic creation while engaging the audience in interactive participation.

**CONCLUSION:** The results of this study show that the combination of sound sensors and IoT technology offers new possibilities for artistic creation. By integrating proper elements in painting and music, artists can create more profound and engaging works. This innovation expands the boundaries of art and provides the audience with a more intimate and interactive experience with the artwork. In the future, further research can delve into the application of sound sensors in other artistic fields, thus promoting the integration of art and technology to move forward.

**Keywords:** sound art, internet of things, sound sensors, painting and music

Received on 7 January 2024, accepted on 3 April 2024, published on 4 April 2024

Copyright © 2024 Li *et al.*, licensed to EAI. This is an open access article distributed under the terms of the [CC BY-NC-SA 4.0](https://creativecommons.org/licenses/by-nc-sa/4.0/), which permits copying, redistributing, remixing, transformation, and building upon the material in any medium so long as the original work is properly cited.

doi: 10.4108/eetsis.5372

\*Corresponding Author. Email: z00471@sdca.edu.cn

## 1. Introduction

In contemporary art, the rapid development of technology provides artists with unprecedented creative possibilities and brings new opportunities for interdisciplinary communication and cooperation (Okuzono, 2022). Among them, the combination of sound art and IoT technology has become an area of great interest, and its application in art creation is gradually showing incredible potential (Abbott, 2021). This study aims to investigate the application of sound sensors in the fusion of painting and music and to explore its practical significance and importance in artistic creation.

In contemporary art, the rapid development of technology provides artists with unprecedented creative possibilities and brings new opportunities for interdisciplinary communication and cooperation (Ahamed & Chishti, 2021). Among them, the combination of sound art and IoT technology has become an area of great interest, and its application in art creation is gradually showing amazing potential (Y. Wang & Ku, 2021). This study aims to investigate the application of sound sensors in the fusion of painting and music and to explore its practical significance and importance in artistic creation. As one of the important branches of modern art, sound art emphasizes artistic expression through the creation, transformation, and transmission of sound (Bernier et al., 2023). Traditionally, sound art is mainly presented in music and sound installation, but with the continuous progress of science and technology, the form and content of sound art are also evolving. At the same time, with the rise of the Internet of Things (IoT) technology, the application of various sensors is no longer limited to the industrial and commercial fields but gradually penetrates all levels of artistic creation (Pon et al., 2022). The development of IoT technology has brought new creative tools and media for artists, among which sound sensors, as an important device capable of capturing environmental sound, provide new possibilities for the practice of sound art (Sa, 2021). By combining Internet of Things technology and sound art, artists can create richer and more diverse art forms, expanding the boundaries of artistic creation and enriching the audience's sensory experience.

This study is important in several ways. First, exploring the possibility of integrating art and technology is important. Traditionally, art and technology are often regarded as two distinct fields, but with the development of technology, the boundary between the two has become increasingly blurred (Johnson et al., 2021). The application of sound sensors in the fusion of painting and music provides artists with a new path of thinking, prompting them to re-examine the relationship between traditional art forms and modern technology. Secondly, this study is of great significance in enriching the expression of artworks. The application of sound sensors makes artworks no longer limited to static forms but more colorful and vivid (Qi & Yang, 2021). By incorporating the sound in the

environment into the scope of art creation, artists can create more infectious and expressive works, triggering more in-depth thinking and experience in the audience. Finally, this study has practical significance in promoting the cross-fertilization of art and technology (Choi, 2022). With the continuous progress of technology, artists will face more and more technical choices and creative challenges (Shen et al., 2022). By deeply exploring the application of sound sensors in art creation, researchers can better understand the relationship between IoT technology and art creation and provide artists with more technical support and creative inspiration.

The practical significance of this study is mainly reflected in the following aspects. Firstly, it provides artists with a new creative idea and methodology. The application of sound sensors no longer limits art creation to traditional brushes and musical instruments but creates more expressive and innovative works through the combination of IoT technology and environmental sound. Second, this study provides a new direction of exploration for art education (Sethi et al., 2023). Traditional art education is often limited to teaching techniques and expressions while ignoring the combination of technology and art (Chang, 2022). By combining IoT technology with sound art, researchers can inject new vigor and innovation into art education and cultivate students' interest in and understanding the cross-fertilization of art and technology. Finally, this study also provides new development opportunities for the art market. With the development of science and technology, the art market is also changing and developing, and traditional artworks can no longer fully meet the audience's needs (Gao & Fu, 2022). The application of sound sensors in the fusion of painting and music brings new products and services to the art market, enriches the audience's choices and experiences, and promotes the further development and growth of the art market (Mazon-Olivo & Pan, 2022). In summary, exploring the Internet of Things in sound art has important theoretical significance and a wide range of practical and social significance.

## 2. Background of the study

Art has always been a key component of culture and innovation, and its forms of expression have evolved in response to the rapid development of technology. In recent years, sound art, as an art form that uses sound as a medium for creation, has attracted much attention in contemporary art. With the rise of Internet of Things (IoT) technology, sound art has ushered in new development opportunities, especially the application of sound sensors, which provides unprecedented possibilities for the fusion of painting and music creation (Kinns et al., 2022). This study aims to deeply explore the application of sound sensors in the fusion of painting and music and to explore its theoretical significance and practical application value for art creation (X. Wang & Cai, 2022). Traditionally, sound art mainly relies on musical instruments or sound devices for

expression, but with the advancement of technology, especially the rise of the Internet of Things (IoT) technology, the introduction of sound sensors brings a brand-new creative space for sound art. Introducing this technology not only expands the form of sound art but also challenges the boundaries between traditional art forms and provides new ideas and directions for developing art theory. Through an in-depth study of the use of sound sensors in the fusion of painting and music, researchers are expected to understand better the mechanism of the fusion of art and technology and provide new perspectives and thinking frameworks for constructing future art theories (Zou et al., 2022). In this study, researchers will explore the practical application of sound sensors in the fusion of painting and music creation and the theoretical significance behind this application. By surveying and analyzing existing related literature and artworks, the researchers will systematically explore how sound sensors affect the process and outcome of art creation. The researchers will deeply analyze the mechanism of sound sensors' role in art creation from various perspectives, such as technology, aesthetics, and creative methodology, and try to put forward conclusions and suggestions that inspire art creators and art theory research. In conclusion, this study will help deepen the understanding of the integration of sound art and IoT technology, explore the new possibilities of art creation and technological development, and provide useful references and insights for future art practice and theoretical research.

This study aims to comprehensively investigate the application of sound sensors in the art of fusion of painting and music to clarify their actual and potential effects on artistic creation (Xu et al., 2021). First, the researcher will conduct an extensive survey and literature review to systematically sort out relevant studies in sound art, IoT technology, and the fusion of painting and music to provide an adequate theoretical foundation for the study (Leong et al., 2021). Secondly, through field observation and practical art creation, the researchers will verify the feasibility and practicality of sound sensors in the creative process. Finally, through an in-depth analysis of the experimental results, the researchers will summarize the application effects of sound sensors in the art of fusion of painting and music and distill relevant art creation principles and guiding suggestions to provide useful references for future sound art creators and art education. Through this study, the researchers aim to provide an in-depth theoretical discussion on integrating sound art and IoT technology and practical guidance for artists and researchers (Nemazi & Nordby, 2021). In addition, the researchers hope this study will contribute to the promotion of cross-fertilization between art creation and technology and provide innovative ideas and methods for art creators in this digital era. In the current context where

tradition and modernity, art and technology are intertwined, the researchers believe that this study will provide useful insights and support for the future development of art creation.

### 3. Research methodology

#### 3.1 Literature review and theoretical analysis

In this study, the researcher first used the method of literature review and theoretical analysis to gain a comprehensive understanding of the current state of research and theoretical foundations in sound art, IoT technology, and the fusion of painting and music. The following are the specific steps of the researcher's study:

In the literature search and screening, the researcher will conduct an extensive literature search through academic databases to collect research papers, books, and reports related to sound art, IoT technology, and art fusion. The search terms will include "sound art," "IoT technology," "sound sensors," "fusion of painting and music," and so on. In Literature Screening and Summarization, the researcher will carefully screen and select the most relevant and authoritative literature for in-depth reading after collecting relevant literature. By summarizing the literature, the researcher will establish a complete theoretical framework that clarifies the relationship between sound art and IoT technology and their potential applications in the fusion of painting and music. Based on the summarized literature, the researcher will conduct a theoretical analysis to delve into the theoretical foundations and practical applications of sound sensors in art creation. The researcher will focus on the intersection of sound art and IoT technologies, exploring their possible impacts, challenges, and opportunities in the fusion of painting and music. The theoretical analysis will provide strong theoretical support for subsequent practical research. In Research Questions and Hypotheses Clarification, based on the results of the literature review and theoretical analysis, the researchers will clarify the main questions and hypotheses in the study, laying the foundation for the subsequent empirical research. This will help to translate the theoretical framework into concrete research design and practical operation. Through the literature review and theoretical analysis, the researcher will ensure that the study has a solid theoretical foundation, can fully draw on previous research experiences, and provide a clear direction and goal for the empirical study. The application of sound sensors in the fusion of painting and music (I), as shown in Figure 1.

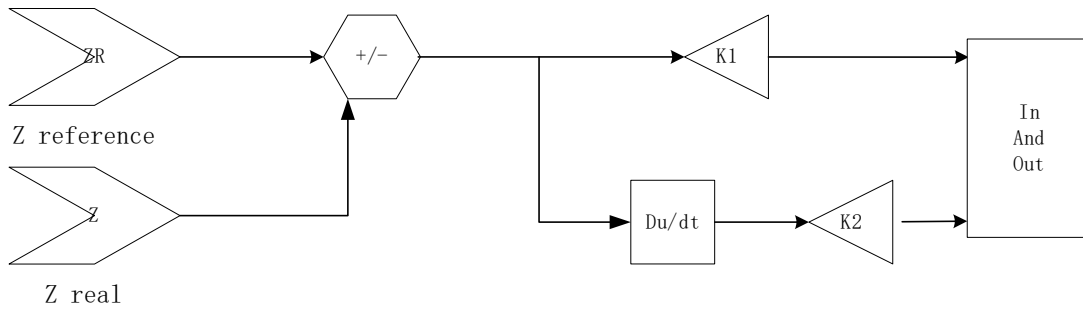

**Figure 1** Application of sound sensors in the fusion of painting and music (a)

In Case Study and Empirical Research, based on literature review and theoretical analysis, some relevant cases or empirical studies are introduced to demonstrate the practical application of sound art, IoT technology, and the integration of painting and music. The development trend, technology application, and artistic innovation in these fields can be more intuitively understood by analyzing these cases. An interdisciplinary research method is considered to integrate and cross knowledge from different fields, such as sound art, IoT technology, and the fusion of painting and music. For example, the theories and methods of several disciplines, such as acoustics, art, engineering, etc., can be combined to explore their relationship and interaction mechanisms in depth. In practical exploration and innovative design based on theoretical analysis, some practical exploration and innovative design are carried out to explore the specific realization and effect of sound art, IoT technology, and the fusion of painting and music. Some artworks or creative projects can be designed and implemented with existing technical tools or platforms to

verify the feasibility and practicality of the theoretical analysis. In the socio-cultural impact analysis, consider analyzing the social and cultural impacts of sound art, IoT technology, and the integration of painting and music from a socio-cultural perspective. It explores how these technologies and art forms shape and change people's aesthetic concepts, cultural habits, and ways of artistic creation and dissemination to deeply understand their significance and value in contemporary society. In the Outlook of Future Development Trends, the comprehensive analysis of existing literature and theories is combined to look into the future development trends and prospects in sound art, Internet of Things technology, and the fusion of painting and music. It can be explored regarding technological innovation, artistic practice, and market demand to provide researchers and practitioners in related fields with references and insights for future development. The application of sound sensors in the fusion of painting and music (II) is shown in Figure 2.

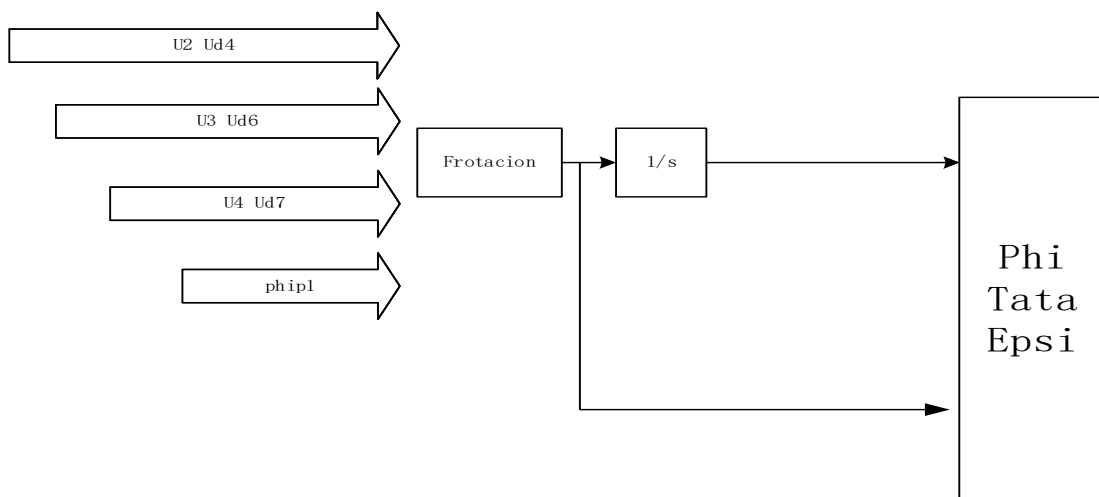

**Figure 2** Application of sound sensors in the fusion of painting and music (II)

### 3.2 Empirical Research and Artistic Creative Practice

Based on the literature review and theoretical analysis, the researchers will conduct empirical research and art creation practice to verify the effectiveness of sound sensors in the fusion of painting and music. The following are the specific research steps:

In Sound Sensor Selection and Technology Preparation, in this phase, the researcher will first select appropriate sound sensors based on the research needs and prepare the related technology. This will include developing sensor selection criteria, conducting performance tests, and checking the sensor's compatibility with other hardware devices (e.g., drawing tools and music devices). In the experimental design, the researchers will design a series of experiments to explore the specific application of sound sensors in the art of fusion of painting and music. The experimental design will consider aspects such as how sound sensors interact with art creation, sensor data collection frequency, and audio and visual elements integration. In the art creation practice, in this phase, the researcher will conduct art creation practice based on the experimental design, using sound sensors for the fusion of painting and music. This may involve obtaining real-time data feedback from sound sensors during the painting creation process or generating specific visual and musical elements based on sound data. The researcher will record the artist's experience and feedback during the practicum to enrich the research data. In Data Acquisition and Analysis, the researchers will collect the data generated during the experiment, including the output data of the sound sensors as well as the results of artistic creation. By analyzing the data, the researchers will evaluate the actual effects of sound sensors in art creation and verify whether the previous theoretical analysis is empirically supported.

In the Interpretation and Discussion of Results, finally, the researcher will explain the results of the empirical study and compare them with the findings of the literature review and theoretical analysis. Through the discussion of the results, the researcher will draw implications and insights into the application of sound sensors in the fusion of painting and music for artistic creation, as well as identify problems that may be encountered in practice and room for improvement. Through this empirical research method, the researchers aim to gain insights into the effects of sound sensors' practical application in artistic creation and to provide practical experience and data support for the fusion of sound art and IoT technology.

### 3.3 Exploring the Internet of Things in Sound Art

In today's rapid development of digitalization and Internet of Things (IoT) technology, sound art has gradually received more attention as an interdisciplinary art form.

Internet of Things (IoT) technology brings new possibilities and challenges to sound art, and how to make full use of IoT technology for creating and expressing sound art has become a research field of great interest. Therefore, this study aims to investigate the combination of sound art and IoT technology and the impact of this combination on the creation and expression of sound art. The main objective of this study is to investigate how IoT technology can be used to expand the expression of sound art and to analyze the effects of this technology on sound art. Specific objectives include exploring the potential application areas of IoT technology in sound art, analyzing the effects of IoT technology on sound art creation and expression, and exploring the effects of integrating IoT technology and sound art on the experience of both the art creator and the audience.

This study will adopt the following methods to achieve the above research objectives. Firstly, by reviewing the literature in related fields, the author will understand the latest developments in sound art and IoT technology and explore the possibility of combining the two and the existing research results. On this basis, select some representative sound artworks, analyze the cases in which IoT technology is applied, and gain a deeper understanding of these cases' creative background, technical realization, and artistic effect. Conduct field research, interviews, and observations with sound art creators, technology developers, and audiences to understand people's views and experiences about the application of IoT technology in sound art. Design and conduct empirical research through experiments or practical activities to verify the actual application effect of IoT technology in sound art. For example, a sound artwork can be designed to incorporate IoT technology, and then the audience can be invited to participate, and their feedback and experience data can be collected. The collected data are organized and analyzed to summarize the application of IoT technology in sound art, the influencing factors and potential problems, and to put forward corresponding recommendations and suggestions for improvement.

Through the implementation of the above research methods, this study is expected to obtain the following results: to gain an in-depth understanding of the current situation and development trend of the application of IoT technology in sound art; to analyze the mechanism of the influence of IoT technology on the creation and performance of sound art; to explore the impact of the integration of IoT technology and sound art on the art creators and the audience; and to put forward the strategy of the application of IoT technology in sound art and the suggestion of technological improvement. The possible limitations of this study include: the bias of sample selection may affect the generalizability of the research results; the technical implementation during the empirical research may be affected by the technical level and resource constraints; and the interpretation of the research results may be affected by subjective factors. The significance of this study is to provide theoretical and practical guidance for the combination of sound art and IoT technology and to

provide reference and support for promoting innovation and development in the field of sound art. Meanwhile, the results of the study can also provide decision-making references for related industries and police departments to promote the industrialization of sound art and IoT technology.

A model of the application of sound sensors in the fusion of painting and music is shown below:

$$\delta = \frac{I_{yy} - I_{zz}}{I_{xx}} (\theta\psi) - \frac{lU_2}{I_{xx}} \quad (1)$$

$$\theta = \frac{I_{zz} - I_{xx}}{I_{yy}} (\vartheta\psi) + \frac{lU_3}{I_{yy}} \quad (2)$$

$$\mu = \frac{I_{xx} - I_{yy}}{I_{zz}} (\pi\psi) - \frac{U_1}{I_{zz}} \quad (3)$$

In Equation (1),  $\delta$  is the random error 1 of the Z function;  $\theta$  is the random error 2 of the Z function;  $\mu$   $\theta$  is the random error 3 of the Z function; the specific expression of the Z function is as follows:

$$Z = (\cos \theta \cos \varphi - g) \frac{U_1}{m_r} + \delta + \theta + \mu \quad (4)$$

In Equation (4), the product  $\cos \theta \cos \varphi$  is 1. Therefore, the logarithmic function is to be considered.

$$x = (\sin \psi \sin \phi + \cos \psi \sin \theta \cos \phi) \frac{U_1}{m_r} \quad (5)$$

In Equation (5),  $\sin \psi \sin \phi + \cos \psi \sin \theta \cos \phi < 1$ , x is always less than the function  $\frac{U_1}{m_r}$ .

## 4. Results and discussion

### 4.1 Results of the application of sound sensors in the fusion of painting and music

Through this study, the researchers successfully explored the application of sound sensors in the fusion of painting and music. In the creation, the researchers used advanced sound sensor technology to transform sound elements, such as frequency, intensity, and rhythm, into data and applied these data to the process of painting and music creation. The following are the key findings of the researchers:

The researchers designed and created a series of artworks to capture sounds in the environment through

sound sensors, transform them into data, and apply them to the creation of paintings and music. For painting, the researchers used a smart painting device that automatically adjusts the movement of the brush and the release of paint based on changes in sound data to create unique visual effects. In music, researchers correlate sound data to notes, chords, and rhythms to create music that echoes the paintings. The researchers used advanced sound sensor technology, such as embedded microphones and vibration sensors, to capture sounds in the environment in real-time. Using microcontrollers and computer algorithms, the researchers could analyze and process the sound data in real time and apply the results to the creation of paintings and music. This technological realization provides strong support for IoT applications of sound art. The researchers presented the created artwork and received positive feedback from the audience and professional artists. The audience experienced the uniqueness of the paintings visually, as well as the music that accompanied them aurally. Professional artists expressed strong interest in this fusion approach to creation, which offers a broader range of possibilities for creativity.

The application of sound sensors in the fusion of painting and music marks the deep integration of art and technology. By combining advanced sensing technology with artistic creation, researchers have gained more creative inspiration and means of expression in the creative process. This fusion expands the expression of sound art and injects new vitality into the traditional art field. The application of sound sensors makes the audience's experience in the artwork richer and more interactive. The audience no longer just passively accepts the artist's creation but feels the vitality of the work through the participation of sound. This interactivity creates a closer connection between the art and the audience, increasing the audience's involvement and engagement. However, researchers also face some technical challenges. There is still room for optimization in the real-time processing of sensor data and the synergy of art creation. Future research could focus on improving sensor technology, increasing data processing efficiency, and deepening the integration of art and technology. In addition, the researchers also encourage more artists and technology developers to participate in the research and practice in this field to jointly promote the development of sound art and IoT. Through the application of sound sensors in the fusion of painting and music, this study demonstrates the cutting-edge results of the fusion of art and technology. The created artworks present a unique visual charm and enrich the audience's auditory experience through the introduction of sound. This research provides useful experience and inspiration for the future deep cooperation between sound art and IoT technology. The application of sensor technology (i), (ii), and (iii) are shown in Figures 3, 4 and 5.

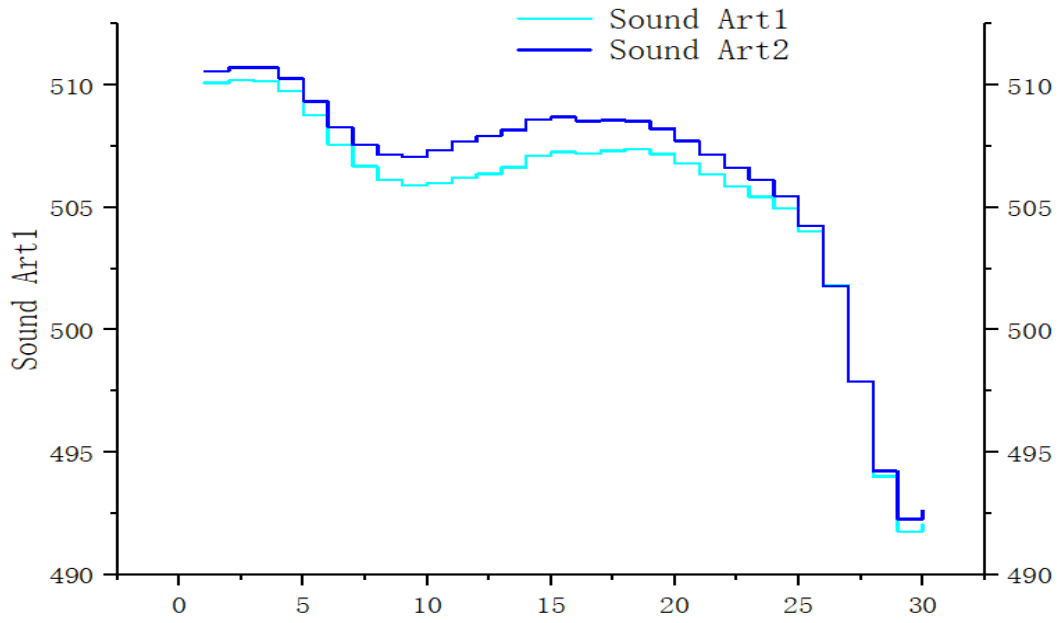

Figure 3 Application of sensor technology (I)

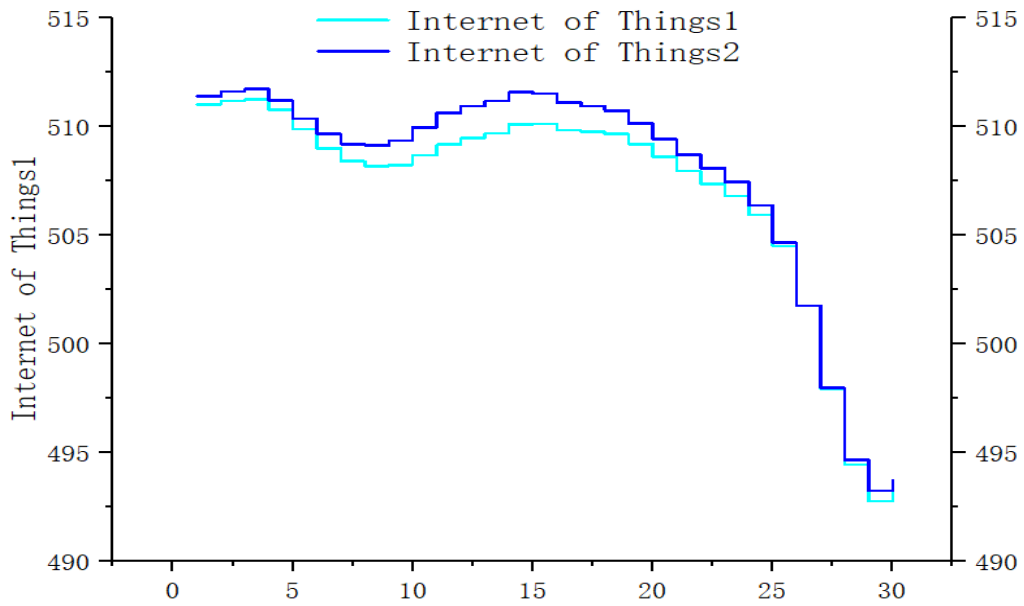
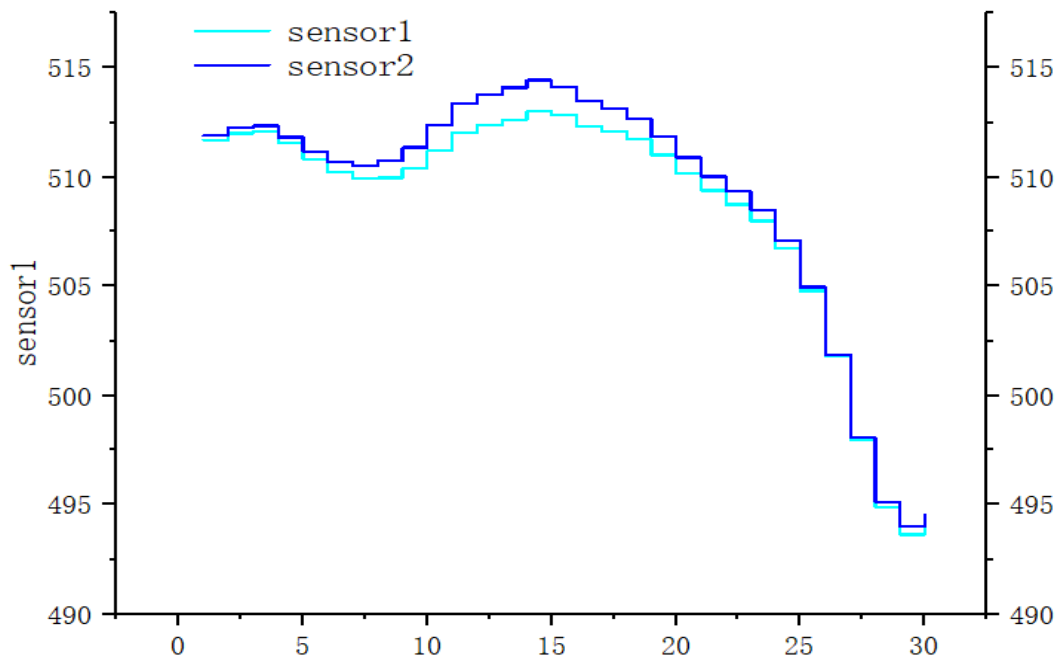

Figure 4 Application of sensor technology (II)



**Figure 5** Application of sensor technology (III)

## 4.2 Application of Sensor Technology Analysis

Internet of Things (IoT) research in sound art is a cross-cutting field involving art, technology, and the Internet. In this study, the researchers explore how IoT technologies can enrich and expand the creation and experience of sound art. By integrating sensors, web technologies, and sound art, the researchers aim to create a new art form that allows audiences to experience the artistic expression of sound more intuitively. In their research, the researchers used a variety of advanced sensor technologies, including sound sensors, vibration sensors, and environmental sensors. These sensors capture sound, vibration, and other sound-related data from the surrounding environment. Combining this data with art creation made the researchers realize a more interactive and perceptual sound art experience. The researchers built a system based on an IoT platform to realize the Internet of Things for sound art. This system includes sensor nodes, data transmission modules, and an art creation engine. The sensor nodes collect environmental data, the data transmission module transmits the data to a central processing unit, and the art creation engine creates unique sound artworks by analyzing the data and combining it with the artist's creativity. With the researchers' IoT sound art system, they have successfully created a series of works showcased in art exhibitions and performances. These works combine sound-sensing data and the artist's creativity to present a multi-layered, multi-sensory art experience.

While enjoying the works, the audience can interactively participate in the sound art creation process through the IoT platform.

Internet of Things (IoT) research in sound art marks the deep integration of art and technology. The application of sensor technology makes artistic creation more interactive and perceptive, and the audience can interact with the works in real time through the Internet of Things platform. This integration expands the expression of sound art and injects new innovative elements into traditional art. Through the Internet of Things sound art system, the audience is no longer just a passive viewer of the work but can participate in the art creation process. They can interact with the work through their voice, movement, or touch, thus creating their own unique experience. This participatory art experience enriches the audience's perception and brings the distance between art and the audience closer.

However, there are some technical challenges that researchers face in advancing IoT research in sound art. First, further improvements and innovations in sensor technology are necessary to increase the accuracy and sensitivity of the data. Second, more efficient algorithms and network architectures are needed for real-time data processing and transmission. In the future, researchers expect to see more technological innovations to promote the deep integration of sound art and IoT. IoT research in sound art is not only a technological breakthrough but also has a positive impact on society and culture. This new art form transcends traditional concepts and breaks the boundaries between art and technology. It has the potential to promote both cultural innovation and art education, opening up new



possibilities for future art development. IoT research in sound art brings new possibilities for artistic creation and experience. Researchers have created a more interactive and perceptual form of sound art by applying sensor technology and IoT platforms. However, researchers need to continue to innovate and improve in the face of technological

challenges. With the continuous development of IoT technology, sound art will also usher in a broader development prospect driven by technology. Painting and music fusion applications (I), (II), and (III), as shown in Figures 6, 7, and 8.

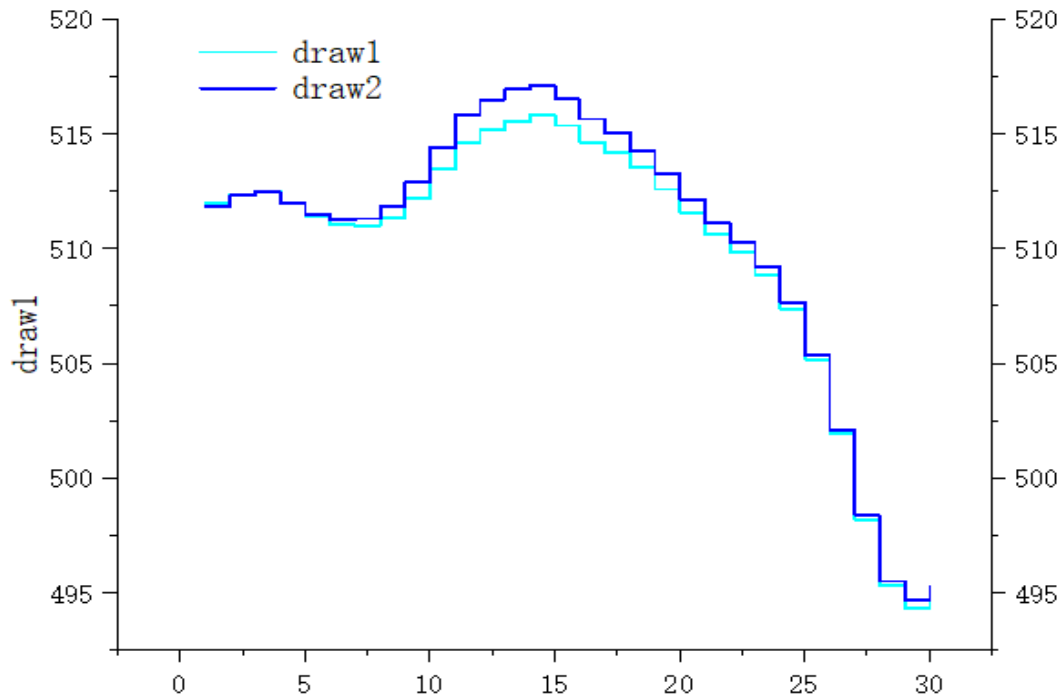
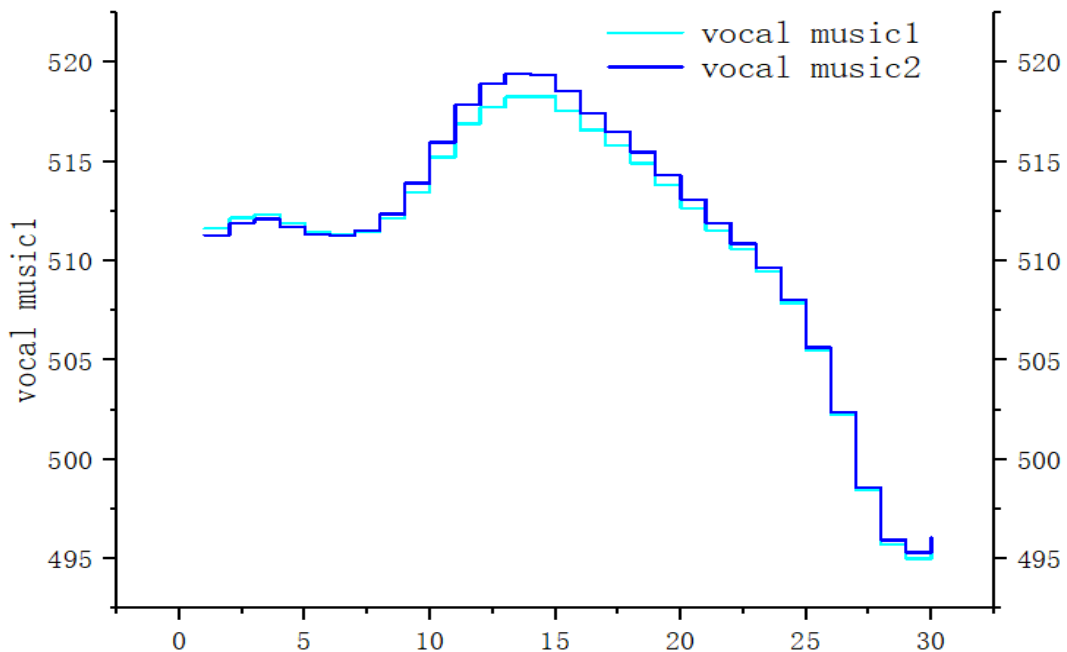
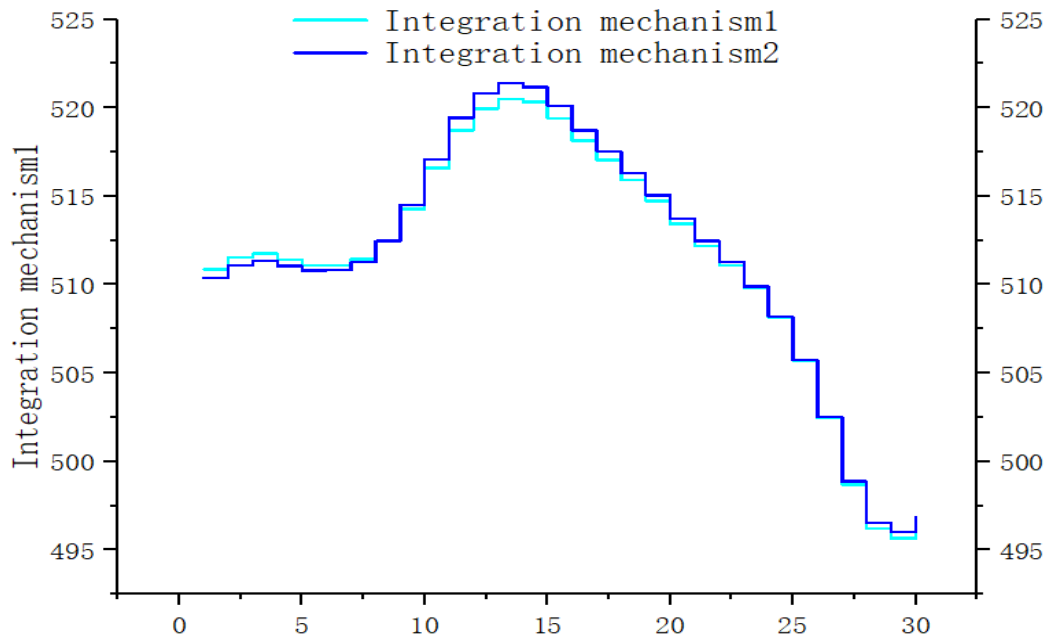

Figure 6 Painting and music fusion application (I)



**Figure 7** Painting and music fusion application (II)**Figure 8** Painting and music fusion application (III)

### 4.3 The mediating role of vocal transducers

Sound sensors play a key role in the fusion of painting and music. Sound sensors can capture and convert sound signals from the surrounding environment into digital signals for processing. These sound signals can come from various sources, including human voices, nature sounds, and sounds generated by other art installations. By combining sound sensors with paintings and music, a new art form can be created, enabling the audience to perceive and understand the artist's creative intent through sound while enjoying the work. The application of sound sensors enables sound and painting to be more closely integrated. In traditional paintings, the audience can only perceive the beauty and expressiveness of the work through vision. Through sound sensors, artists can integrate sound elements into paintings, enabling the audience to perceive the connotation and emotion of the work through hearing. This integration of sound and painting not only enriches the expression of the work but also expands the audience's perception space, enabling them to understand and appreciate the artwork more diversified.

In addition to combining with painting, sound sensors can be combined with music to create an entirely new form of music. By capturing sound signals from the surrounding environment and transforming them into elements of music, artists can create musical compositions with unique timbres and rhythms. This fusion of sound and music brings new inspirations and possibilities for music creation and

provides a brand-new way for the audience to experience music. The audience cannot only perceive the beauty of music through hearing but also understand and feel the emotions and connotations that the music is trying to express through sound elements. The works artists create through sound sensors can be displayed in a richer and more three-dimensional effect. The audience can not only appreciate the appearance and structure of the work through vision but also perceive the sound and rhythm of the work through hearing. This multi-sensory experience enables the audience to understand and appreciate the work of art more comprehensively and thus immerse themselves more deeply in it, experiencing the beauty and shock of art.

The role of sound sensors in the fusion of painting and music is to enrich the multi-sensory experience of the viewer. Traditional paintings and music works are often perceived and understood only through vision or hearing, while through sound sensors, viewers can not only appreciate the appearance and structure of the work through vision but also perceive the sound and rhythm of the work through hearing. This multi-sensory experience enables the audience to understand and appreciate the artwork more comprehensively, thus enhancing the work's artistic value and viewing experience.

The application of sound sensors brings new technical means and possibilities for artistic creation. Artists can use sound sensors to capture the sound signals in the surrounding environment and transform them into part of the artwork, thus creating works with unique tones and rhythms. This technological innovation not only injects new vitality and inspiration into artistic creation but also

provides the audience with a new way of experiencing art, expanding the forms of expression and boundaries of art. Sound sensors can also enhance the interactivity and participation of artworks. The audience can not only passively appreciate the works but also interact with them in real time through the sound sensor to participate in the art creation process. This participatory art experience brings the distance between the audience and the work closer and provides a more personalized and immersive art experience, enriching the audience's cultural life and spiritual enjoyment. The role of sound sensors in integrating painting and music is not only a breakthrough on the technical level but also has a positive impact on social culture.

## 5. Conclusion

In this study, the researchers conducted an in-depth discussion on the cross-fertilization of sound art and IoT technology, focusing on applying sound sensors in the art of fusion of painting and music. Through the review of related literature, field observation, and art creation practice, the researchers attempt to clarify the actual effects and potential impacts of sound sensors in the field of art creation, and put forward related art creation principles and guiding suggestions. First, from a theoretical perspective, the researchers systematically sorted out relevant studies in sound art, IoT technology, and the fusion of painting and music through surveys and literature reviews. This provides the researchers with a theoretical foundation for a deeper understanding of the position and role of sound sensors in artistic creation and lays the groundwork for subsequent practical research. Second, through field observation and practical art creation, the researchers verified the feasibility and practicality of sound sensors in the creative process. In practice, the researchers found that applying sound sensors enriches the form of expression of artworks and expands the artist's creative imagination space, injecting new vitality and vigor into artistic creation. Eventually, through analyzing the experimental results, the researchers summarized the effect of the application of sound sensors in the fusion of painting and music and refined the relevant principles of artistic creation and guiding suggestions. The researchers found that introducing sound sensors can not only realize the organic fusion of painting and music but also stimulate the audience's multi-sensory experience and enhance artwork's infectious and expressive power. At the same time, the researchers also found some technical and artistic challenges in practice, such as the accuracy of the sensors and the complexity of data processing, which present new topics and challenges for future research and practice. Overall, this study explored the integration of sound art and IoT technology, proposed an application of sound sensors in the art of fusion of painting and music, and evaluated and summarized its effectiveness. Through this study, the researchers provide new ideas and methods for the cross-application of sound art and IoT technology and make some contributions to promote the integration of art creation and technology. In future studies, the researchers

will further explore a wider range of applications of sound sensors in art creation and work to solve the technical and artistic challenges encountered in practice, providing more possibilities for the continuous development and innovation of art creation.

## References

- [1] Abbott, H. (2021). *Samuel Beckett and the arts of time: Painting, music, narrative*. 1–10. <https://doi.org/10.4324/9781003162483-2>
- [2] Ahamed, J., & Chishti, M. A. (2021). Semantic interoperability in the Internet of things—State-of-the-art and prospects. *International Journal of Innovative Computing and Applications*, 12(2/3), 77. <https://doi.org/10.1504/IJICA.2021.113747>
- [3] Bernier, N., Boutard, G., Traube, C., Schorpp, E., Bellemare, L., & Drouin-Trempe, V. (2023). Sine wave in music and sound art: A typology of artistic approaches. *Organized Sound*, 28(1), 133–145. <https://doi.org/10.1017/S1355771822000590>
- [4] Chang, Y. W. E. (2022). Space-age aesthetics in modern art inspired by space exploration: A brief study on installation, painting and music art. *Acta Astronautica*, 35, 1177. <https://doi.org/10.1016/j.actaastro.2022.06.039>
- [5] Choi, J. (2022). Making sound art sound: Contemporary sound art in the post-medium condition. *Journal of the Science and Practice of Music*, 34(34), 45–66. <https://doi.org/10.36944/JSPM.2022.04.47.151>
- [6] Gao, N., & Fu, L. (2022). Study the fusion of oil painting art and digital media based on a visual sensor. *J. Sensors*, 2022, 1–10.
- [7] Johnson, J. B., Anderson, J. F., Marshall, H. P., Havens, S., & Watson, L. M. (2021). Snow avalanche detection and source constraints are made using a networked array of infrasound sensors. *Journal of Geophysical Research: Earth Surface*, 126(3), 34–51. <https://doi.org/10.1029/2020JF005741>
- [8] Kinns, N. B., Fencott, R., Metatla, O., & Sheridan, J. (2022). *Interactional sound and music: Listening to CSCW, sonification, and sound art*. 56, 22–39.
- [9] Leong, Y. R., Tajudeen, F. P., & Yeong, W. C. (2021). Bibliometric and content analysis of the Internet of things research: A social science perspective. *Online Information Review*, 45(6), 1148–1166. <https://doi.org/10.1108/OIR-08-2020-0358>
- [10] Mazon-Olivo, B., & Pan, A. (2022). Internet of things: State-of-the-art, computing paradigms, and reference architectures. *Latin America Transactions*, 20–1, 1144–1158.
- [11] Nemazi, F., & Nordby, J. (2021). *Determining the origin of impulsive noise events using paired wireless sound sensors*. 123, 23–44.
- [12] Okuzono, T. (2022). A basic study on the design of dotted-art heterogeneous MPP sound absorbers. *Acoustics*, 4, 220–241.
- [13] Pon, A., Ichino, J., Sharlin, E., & Eagle, D. (2022). *Vuzik: Music creation and comprehension through painting*. 34, 12–33.
- [14] Qi, T., & Yang, J. (2021). Relationship between sound perception and acoustics of seat-belt warning sound. *Human Factors and Ergonomics in Manufacturing & Service Industries*, 31(6), 11–45. <https://doi.org/10.1002/hfm.20936>
- [15] Sa, A. (2021). *A method to analyze sound art and audio-*

- visual performance*. 34–56.
- [16] Sethi, S. S., Kumar, D., & Lata, L. K. (2023). An assessment of the state of the art of the Internet of Things (IoT). *SKIT Research Journal*, 34, 221–245. <https://doi.org/10.47904/IJSKIT.13.1.2023.23-28>
- [17] Shen, D., Guo, H., Yu, L., Ying, J., Shen, J., Ying, S., Bao, D., & Wang, Y. (2022). Sound design of guqin culture: Interactive art promotes the sustainable development of traditional culture. *Sustainability*, 14, 11–34.
- [18] Wang, X., & Cai, L. (2022). Application of artificial intelligence in 6G Internet of Things communication in interactive installation art. *International Journal of Grid and Utility Computing*, 34–66.
- [19] Wang, Y., & Ku, J. (2021). Research on collaborative innovation platform of the Internet of Things industry based on data mining technology. *Journal of Physics: Conference Series*, 1881(4), 042072-.
- [20] Xu, S., Zhou, D., Fang, J., Yin, J., & Zhang, L. (2021). *FusionPainting: Multimodal fusion with adaptive attention for 3D object detection*. 222, 21–45. <https://doi.org/10.1109/ITSC48978.2021.9564951>
- [21] Zou, Y., Wang, P., Fan, Z., Li, X., Fang, S., Yu, Y., Zhang, H., Gong, Y., Liu, Y., & Guo, J. (2022). Highly mechanical properties, anti-freezing, and ionic conductive organohydrogel for wearable sensors. *Reactive and Functional Polymers*, 34, 12–44. <https://doi.org/10.1016/j.reactfunctpolym.2022.105267>